



Hydraulic Motor/Pump Series F11/F12

Fixed Displacement

Catalogue HY17-8249/UK
May 2001



Content	Page
General information	3
F11 cross section	3
F12 cross sections	4
Specifications	5
Ordering codes:	
- F11	6
- F12	7
Bearing life	8
Efficiency	9
Noise level	9
Selfpriming speed and required inlet pressure	10
Installation dimensions:	
- F11-5 and -10 CETOP	11
- F11-19 CETOP	12
- F11-19 SAE	13
- F12 ISO	14
- F12 Cartridge	16
- F12 SAE 4 bolt flange	18
- F12 SAE 2 bolt flange	20
- F11-150 CETOP	22
- F11-150 SAE	23
- F11-250 SAE	24
F11 saw motors	25
F11 fan motors	25
F12 integrated flushing valve	26
F12 accessory valve blocks:	
- Type FV13 (F12-110)	26
- Type BT brake valve	27
- Type SR pressure relief/ make-up valve	27
- Type SV pressure relief valve	28
F12 speed sensor	28
F12 main port suction fittings	29
Installation information	30

Conversion factors

1 kg	2.20 lb
1 N	0.225 lbf
1 Nm	0.738 lbf ft
1 bar	14.5 psi
1 l	0.264 US gallon
1 cm ³	0.061 cu in
1 mm	0.039 in
$\frac{9}{5}^{\circ}\text{C} + 32$	1 [°] F

Parker Hannifin reserves the right to modify products without prior notice.

Even though the brochure is revised and updated continuously, there is always a possibility of errors.

For more detailed information about the products, please contact Parker Hannifin (Mobile Controls Div.).

General information

F11 and F12 are bent axis, fixed displacement heavy-duty motor/pump series. They can be used in numerous applications in both open and closed loop circuits.

- Series F11 is available in the following frame sizes and versions:
 - F11-5, -10, 19 and -150 with CETOP mounting flange and shaft end
 - F11-19, -150 and -250 with SAE flange and shaft
- Series F12 conforms to current ISO and SAE mounting flange and shaft end configurations. A very compact cartridge version is also available.
Frame sizes: F12-30, -40, -60, -80 and -110.
- Thanks to the unique spherical piston design, F11/F12 motors can be used at unusually high shaft speeds. Operating pressures to 7000 psi provides for the high output power capability.
- The 40° angle between shaft and cylinder barrel allows for a very compact, lightweight motor/pump.

- The laminated piston ring offers important advantages such as low internal leakage and thermal shock resistance.
- The pump version has highly engineered valve plates for increased selfpriming speed and low noise, available with left and right hand rotation.
- The F11/F12 motors produce very high torque at start-up as well as at low speeds.
- Our unique timing gear design synchronizes shaft and cylinder barrel, making the F11/F12 very tolerant to high 'G' forces and torsional vibrations.
- Heavy duty roller bearings permit substantial external axial and radial shaft loads.
- The F11's and F12's have a simple and straightforward design with very few moving parts, making them very reliable motors/pumps.
- The unique piston locking, timing gear and bearing set-up as well as the limited number of parts add up to a very robust design with long service life and, above all, proven reliability.

F11 cross section

1. Barrel housing
2. Valve plate
3. Cylinder barrel
4. Guide spacer with O-rings
5. Timing gear
6. Roller bearing
7. Bearing housing
8. Shaft seal
9. Output/input shaft
10. Piston with laminated piston ring

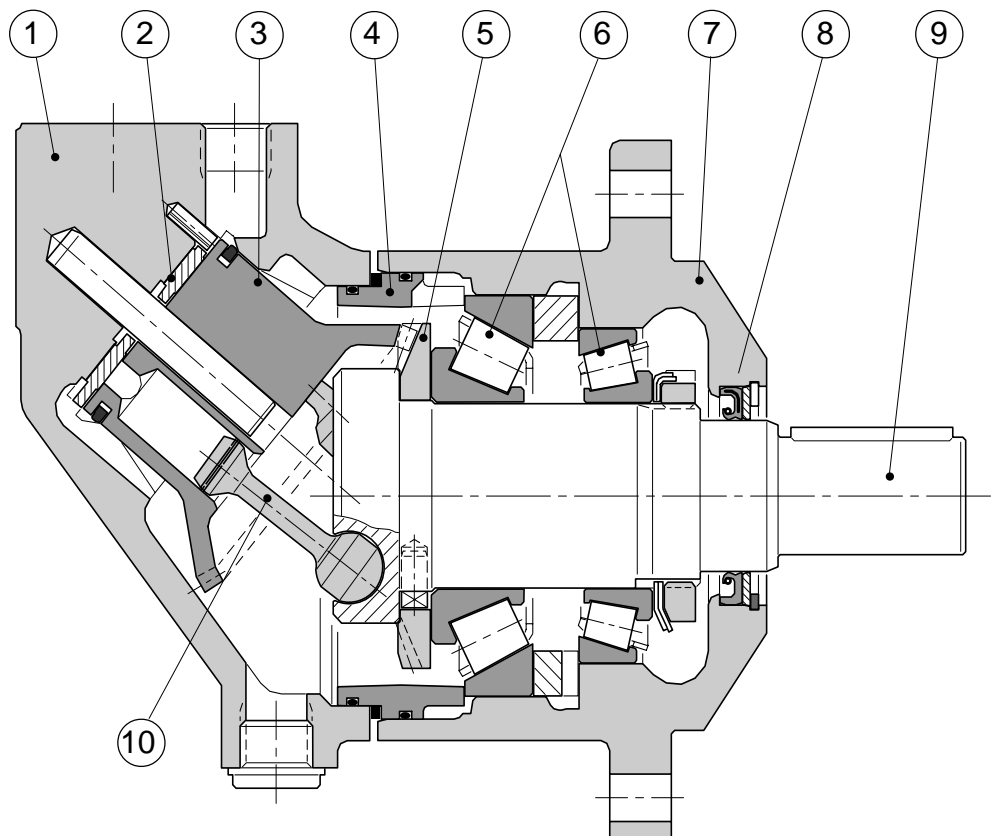

F12 cross sections

F12-30, -40, -60 and -80
 (F12-60 shown)

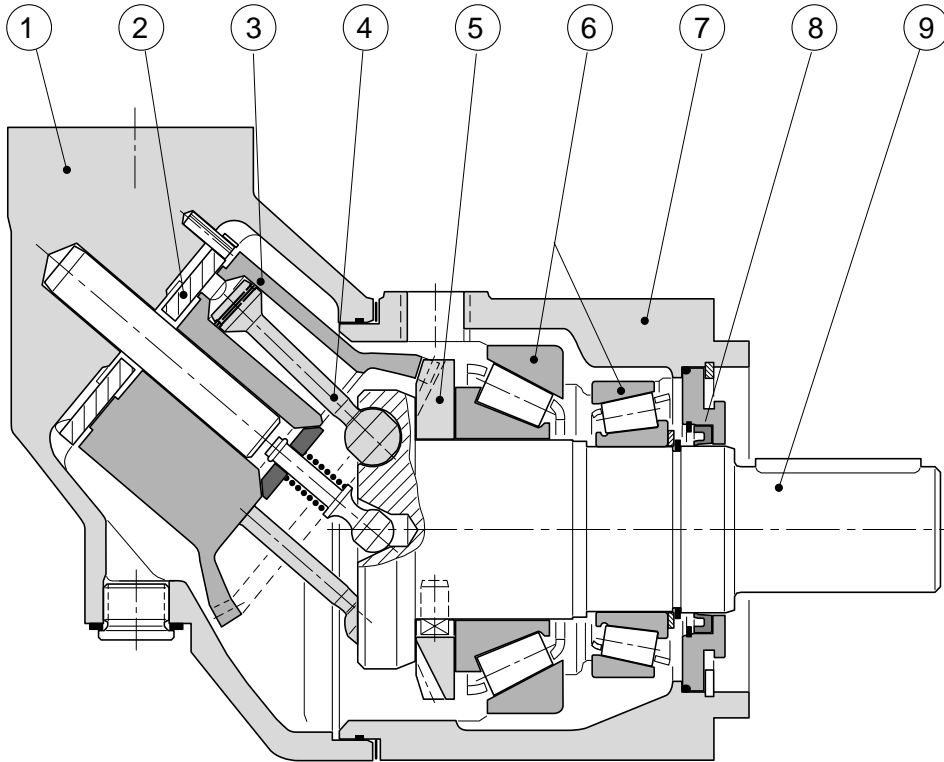

- Legend:
- | | | |
|----------------------------|----------------------------|-----------------------|
| 1. Barrel housing | 5. Timing gear | 9. Output/input shaft |
| 2. Valve plate | 6. Tapered roller bearings | 10. Port E (F12-110) |
| 3. Cylinder barrel | 7. Bearing housing | 11. Needle bearings |
| 4. Piston with piston ring | 8. Shaft seal | |

F12-110

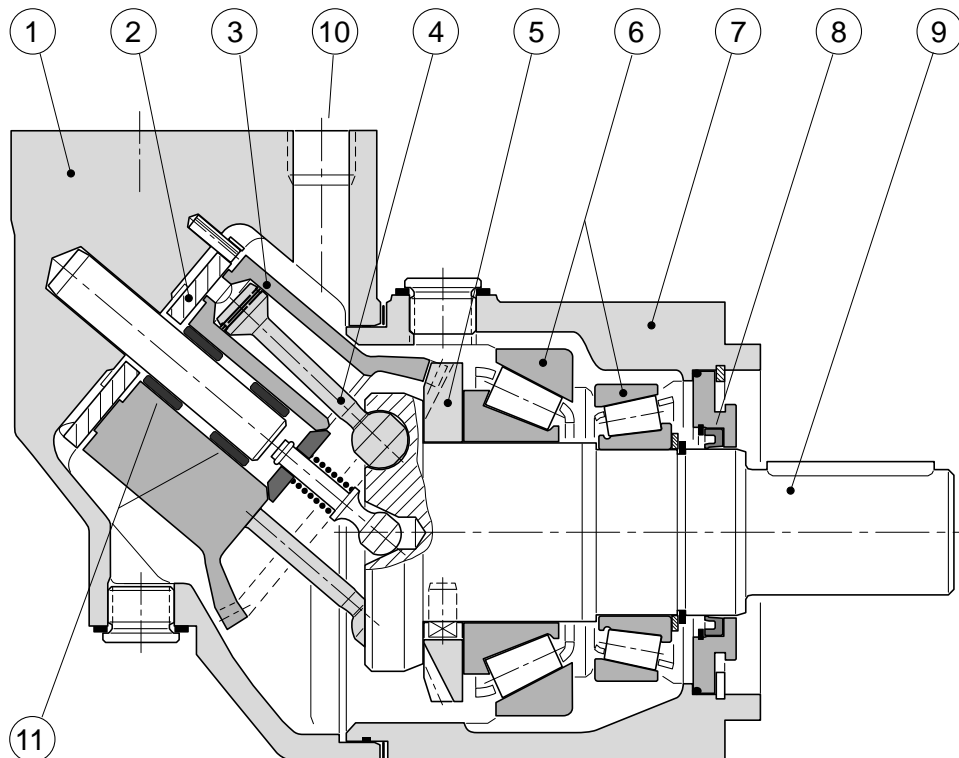

Specifications

Frame size	F11-5	-10	-19	F12-30	-40	-60	-80	-110	F11-150	-250
Displacement [cm ³ /rev]	4.88	9.84	19.0	30.0	40.0	59.8	80.4	110.1	150	242
Motor operating speed [rpm]										
max intermittent	12 000	10 000	7 500	7 100	6 400	5 600	5 200	4 700	3 000	2 700
max continuous	8 500	6 800	5 400	5600	5000	4300	4000	3600	2 600	2 400
min continuous	200	—	200	50	—	—	—	50	200	200
Max pump selfpriming speed										
L or R function; max [rpm]	4 600 ¹⁾	4 200 ¹⁾	3 500 ¹⁾	2850 ¹⁾	2650 ¹⁾	2350 ¹⁾	2350 ¹⁾	2200 ²⁾	1 700 ¹⁾	1 500 ¹⁾
Torque (theor.) at 100 bar [Nm]	7.8	15.6	30.2	47.6	63.5	94.9	128	175	238	384
Motor input flow										
max intermittent [l/min]	58	98	143	213	256	335	418	517	450	650
max continuous [l/min]	41	67	103	168	200	257	322	396	390	580
Output power (motor)										
max intermittent [kW]	18	28	45	110	130	175	220	270	200	300
max continuous [kW]	13	20	32	70	85	110	153	165	145	190
Operating pressure										
max intermittent [bar]	420	—	420	480	—	—	—	480	420	420
max continuous [bar]	350	—	350	420	—	—	—	420	350	350
Max case pressure										
shaft seal type H, 1500 rpm [bar]	20	20	19	14	12	12	10	9.5	9.5	9.5
Main circuit temp., max [°C]	75	—	75	80	—	—	—	80	75	75
min [°C]	-35	—	-35	-40	—	—	—	-40	-35	-35
Fluid viscosity, max. [mm ² /s]	1 000	—	—	—	—	—	—	—	—	1 000
min. [mm ² /s]	10	—	10	8	—	—	—	8	10	10
Fluid contamination level (ISO code 4406)	18/13	—	—	—	—	—	—	—	—	18/13
Mass moment of inertia (x10 ⁻³) [kg m ²]	0.18	0.44	1.2	1.7	2.9	5	8.4	11.2	40	46
Weight [kg]	5	7.5	11	12	16.5	21	26	36	70	77

- 1) For all except F12-110: Selfpriming speed valid at sea level; the drain line **must** end below the lowest fluid level in the reservoir.
- 2) For F12-110: Selfpriming speed valid at 1.0 bar (abs.) inlet pressure; the drain line **must** end below the lowest fluid level in the reservoir.

Ordering codes

F11-CETOP

1. Frame size	5	10	19	150
2. Function				
M Motor	x	x	x	x
H Motor, high pressure	x	x	x	x
Q Motor, silent	(x)	(x)	(x)	(x)
J Motor, clockwise rot'n ¹⁾	(x)	(x)	(x)	(x)
G Motor, counter clockw. ¹⁾	(x)	(x)	(x)	(x)
R Pump clockwise rot'n	x	x	x	x
L Pump counter clockw.	x	x	x	x
3. Main ports				
B BSP threads	x	x	x	-
R With anti-cavitation valve; clockwise rot'n ²⁾	-	x	x	-
L With anti-cavitation valve; counter clockw. ²⁾	-	x	x	-
U SAE, UN threads	(x)	(x)	(x)	-
F SAE 6000 psi flange	-	-	-	x
4. Mounting flange				
C CETOP flange	x	x	x	x
W Saw motor flange	-	x	x	-

Example: **F11 - 10 - M B - C N - K - 000**
 1 2 3 4 5 6 7

1. Frame size	5	10	19	150
5. Shaft seal				
N Nitrile, low pressure	x	x	x	x
H Nitrile, high pressure	(x)	(x)	(x)	(x)
E FPM (low pressure, high temperature)	(x)	(x)	(x)	(x)
6. Shaft				
K Metric key	x	x	x	x
D Spline, DIN 5480	(x)	(x)	(x)	(x)
7. Version number (assigned for special versions)				

x: Available (x): Optional -: Not available
 1) Internal drain
 2) BSP threads

F11-SAE

1. Frame size	5	10	19	150	250
2. Function					
M Motor	-	-	x	x	-
H Motor, high pressure	-	-	x	x	-
Q Motor, silent	-	-	(x)	(x)	x ³⁾
J Motor, clockwise rot'n ¹⁾	-	-	(x)	(x)	-
G Motor, counter clockw. ¹⁾	-	-	(x)	(x)	-
R Pump clockwise rot'n	-	-	x	x	x
L Pump counter clockw.	-	-	x	x	x
3. Main ports					
U SAE, UN threads	-	-	x	-	-
B BSP threads	-	-	(x)	-	-
F SAE 6000 psi flange ⁴⁾	-	-	-	x	x
4. Mounting flange					
S SAE flange	-	-	x	x	x

Example: **F11 - 19 - H U - S N - T - 000**
 1 2 3 4 5 6 7

1. Frame size	5	10	19	150	250
5. Shaft seal					
N Nitrile, low pressure	-	-	x	x	x
H Nitrile, high pressure	-	-	(x)	(x)	(x)
E FPM (low pressure, high temperature)	-	-	(x)	(x)	(x)
6. Shaft					
T SAE key	-	-	x	x	-
S SAE spline	-	-	(x)	(x)	(x)
K Metric key	-	-	-	-	x
F SAE spline	-	-	-	-	(x)
7. Version number (assigned for special versions)					

x: Available (x): Optional -: Not available
 1) Internal drain
 3) Standard
 4) Metric thread

F12-ISO

1. Frame size	30	40	60	80	110
2. Function					
M Motor	x	x	x	x	x
L Pump counter clockw.	x	x	x	x	x
R Pump clockwise	x	x	x	x	x
3. Main ports					
F ISO flange	x	x	x	x	x
4. Mounting flange					
I ISO	x	x	x	x	x
5. Shaft seal					
H Nitrile (high pressure)	x	x	x	x	x
N Nitrile (low pressure)	(x)	(x)	(x)	(x)	(x)
V FPM (high temp., high pressure)	x	x	x	x	x

F12-Cartridge

1. Frame size	30	40	60	80	110
2. Function					
M Motor	x	x	x	x	x
3. Main ports					
F ISO flange	x	x	x	x	x
4. Mounting flange					
C Cartridge	x	x	x	x	x
5. Shaft seal					
H Nitrile (high pressure)	x	x	x	x	x
N Nitrile (low pressure)	(x)	(x)	(x)	(x)	(x)
V FPM (high temp., high pressure)	x	x	x	x	x

F12-SAE

1. Frame size	30	40	60	80	110
2. Function					
M Motor	x	x	x	x	x
L Pump counter clockw.	x	x	x	x	x
R Pump clockwise	x	x	x	x	x
3. Main ports					
S SAE flange	x	x	x	x	x
4. Mounting flange					
S SAE 4 bolt	x	x	x	x	x
T SAE 2 bolt	x	x	x	-	-
5. Shaft seal					
H Nitrile (high pressure)	x	x	x	x	x
N Nitrile (low pressure)	(x)	(x)	(x)	(x)	(x)
V FPM (high temp., high pressure)	x	x	x	x	x

Example: **F12 - 80 - M F - I H - K - 000 - L01 - S**

1 2 3 4 5 6 7 8 9

1. Frame size	30	40	60	80	110
6. Shaft					
D DIN spline Standard	x	x	x	x	x
Z " " Optional	(x)	(x)	-	(x)	-
K Metric key Standard	x	x	x	x	x
P " " Optional	(x)	-	-	-	-
7. Version number (assigned for special versions)					
8. Option (page 26)					
L01 Integr. flushing valve	x	x	x	x	6)
9. Option (page 28)					
S With speed sensor	x	x	x	x	x
P Prepared for speed sensor	x	x	x	x	x

Example: **F12 - 80 - M F - C H - C - 000 - L01 - S**

1 2 3 4 5 6 7 8 9

1. Frame size	30	40	60	80	110
6. Shaft					
C DIN spline Standard	x	x	x	x	x
K Metric key Standard	x	-	x	x	-
X " " Optional	-	(x)	-	-	-
7. Version number (assigned for special versions)					
8. Option (page 26)					
L01 Integr. flushing valve	x	x	x	x	6)
9. Option (page 28)					
S With speed sensor	x	x	x	x	x
P Prepared for speed sensor	x	x	x	x	x

Example: **F12 - 80 - M S - S H - S - 000 - L01 - S**

1 2 3 4 5 6 7 8 9

1. Frame size	30	40	60	80	110
6. Shaft					
S SAE spline Standard	x	x	x	x	x
U " " Optional	-	-	-	(x)	-
T SAE key Standard	x	x	x	x	x
7. Version number (assigned for special versions)					
8. Option (page 26)					
L01 Integr. flushing valve	x	x	x	x	6)
9. Option (page 28)					
S With speed sensor	x	x	x	x	x
P Prepared for speed sensor	x	x	x	x	x

x: Available (x): Optional - : Not available

6) F12-110: Accessory valve block (page 26)

Bearing life

General information

Bearing life can be calculated for that part of the load/life curve (shown below) that is designated 'Bearing fatigue'. 'Rotating group fatigue and wear' and 'Other' caused by material fatigue, fluid contamination, etc. should also be taken into consideration when estimating the service life of a motor/pump in a specific application.

Bearing life calculations are mainly used when comparing different frame sizes. Bearing life, designated B_{10} (or L_{10}), is dependent of system pressure, operating speed, external shaft loads, fluid viscosity in the case, and fluid contamination level.

The B_{10} value means that 90% of the bearings survive, at a minimum, the number of hours calculated. Statistically, 50% of the bearings will survive at least five times the B_{10} life.

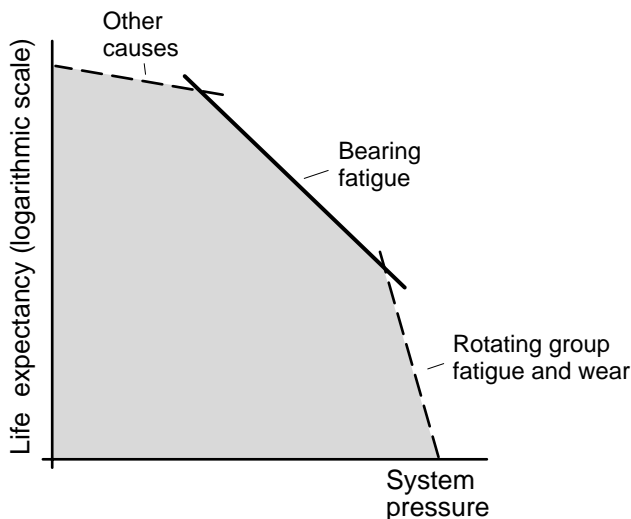

Hydraulic unit life versus system pressure.

Bearing life calculation

An application is usually governed by a certain duty or work cycle where pressure and speed vary with time during the cycle.

In addition, bearing life depends on external shaft forces, fluid viscosity in the case and fluid contamination.

Parker Hannifin (Mobile Controls Division) has a computer program for calculating bearing life and will assist in determining F11 or F12 motor/pump life in a specific application.

Required information

When requesting a bearing life calculation from Parker Hannifin (Mobile Controls Division), the following information (where applicable) should be provided:

- A short presentation of the application
- F11 or F12 size and version
- Duty cycle (pressure and speed versus time at given displacements)
- Low system pressure
- Case fluid viscosity
- Life probability (B_{10} , B_{20} , etc.)
- Operating mode (pump or motor)
- Direction of rotation (L or R)
- External shaft loads
- Fixed or rotating radial load
- Distance between flange and radial load
- Angle of attack (α) as defined below

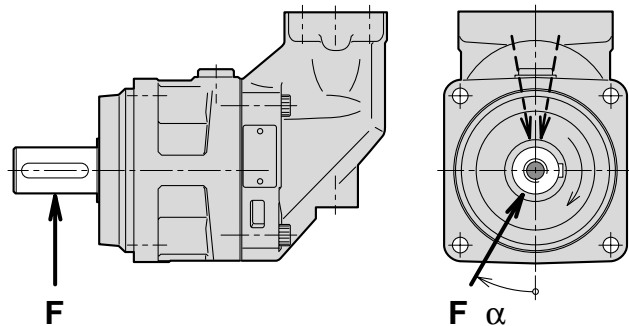

The direction (α) of the radial load is positive in the direction of rotation as shown.

To obtain maximum bearing life, the radial load should, in most cases, be located approximately at 170° (motor; R.H. rot'n) or 190° (pump; R.H rot'n).

Efficiency

Because of its high overall efficiency, driving a motor/pump from series F11/F12 requires less fuel or electric power. Also, it allows the use of a small reservoir and heat exchanger, which in turn reduce cost, weight, and installation size.

The diagrams to the right shows volumetric and mechanical efficiencies of an F12-30.

Contact Parker Hannifin (Mobile Controls Div.) for efficiency information on a particular F11/F12 frame size that is being considered.

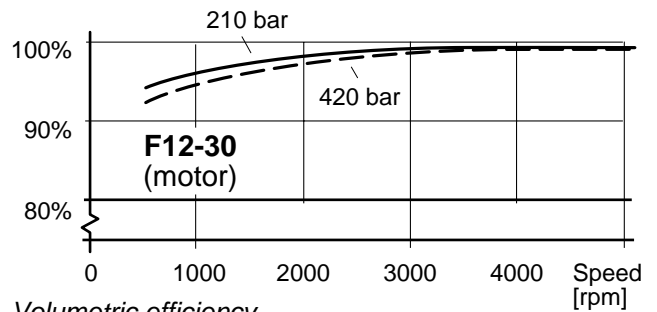

Volumetric efficiency.

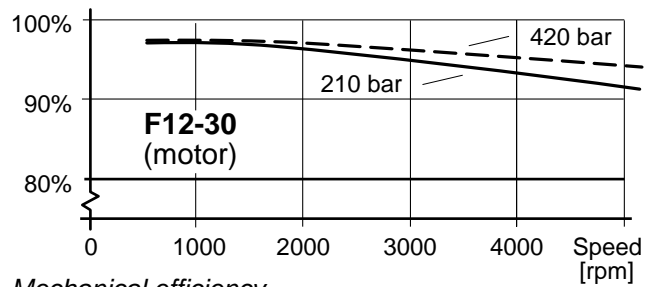

Mechanical efficiency.

Noise level

Series F11/F12 feature low noise levels from low to high speeds and pressures.

As an example, the diagram to the right shows the noise level of an F12-30.

The noise level is measured in a semi-anechoic room, 1 m behind the unit.

The noise level for a particular motor/pump may vary ±2 dB(A) compared to what is shown in the diagram.

NOTE: Noise information for F11/F12 frame sizes are available from Parker Hannifin (Mobile Controls Div.).

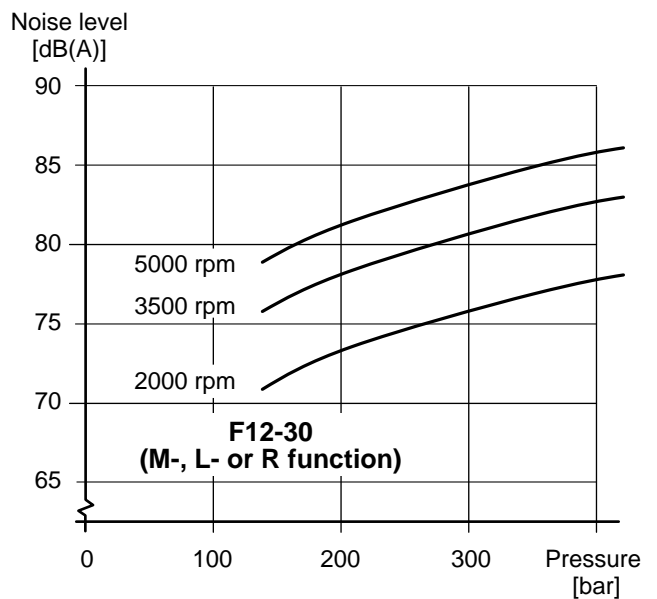

Selfpriming speed and required inlet pressure

Series F11

In pump applications, the F11 with function **L** (counter clockwise rotation) or **R** (clockwise rotation) is normally used. The L and R (pump) provide the highest selfpriming speeds (see table) as well as the lowest noise level. The **M** (motor) function can also be used as a pump, in either direction, but at a lower selfpriming speed.

Operating above the selfpriming speed (refer to Diagram 1) requires increased inlet pressure. As an example, at least 1.0 bar is needed when operating the F11-19-M as a pump at 3500 rpm.

An F11 with **H** function, used as a motor (e.g. in a hydrostatic transmission), may sometimes operate as a pump at speeds above the selfpriming speed; this requires additional inlet pressure.

Insufficient inlet pressure can cause pump cavitation resulting in greatly increased pump noise and deteriorating performance.

Function	L or R	M	H
F11-5	4600	3800	3200
F11-10	4200	3100	2700
F11-19	3500	2400	2100
F11-150	1700	1300	1100
F11-250	1500	950	-

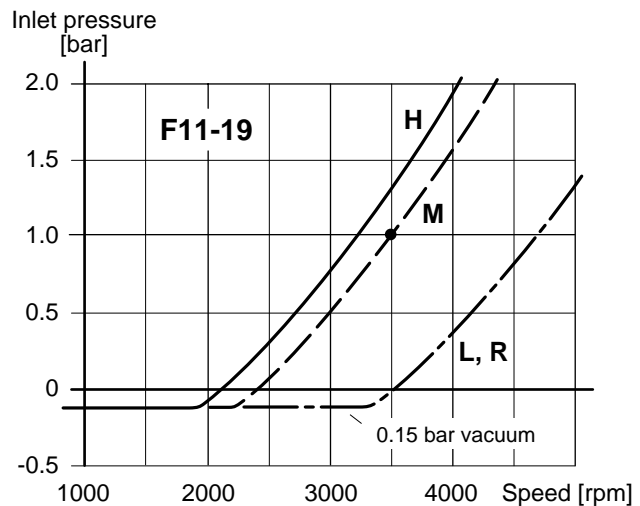
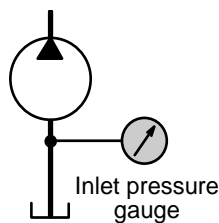

Diagram 1. Min required inlet pressure (F11-19).

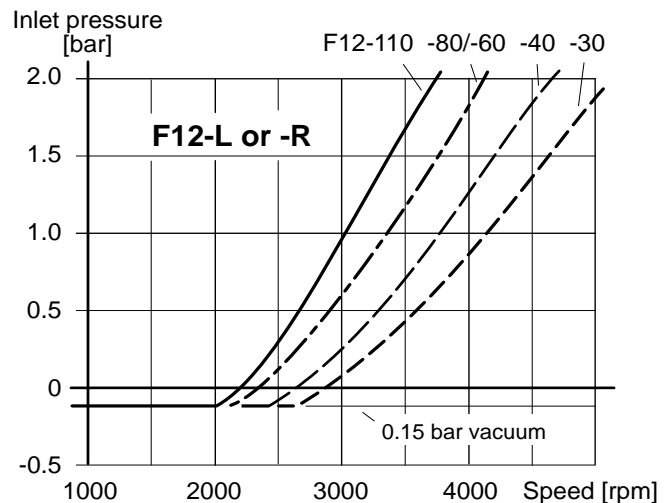

Diagram 2. Min. required pump (F12-L or -R) inlet press.

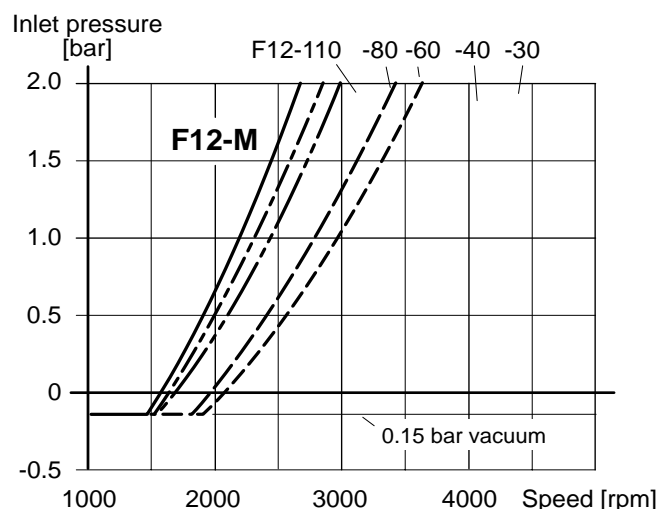

Diagram 3. Min. required motor (F12-M) inlet pressure.

Series F12

When operating the F12 as a pump (with **L** or **R** valve plate) above the selfpriming speed, the inlet must be pressurized. Increased noise and deteriorating performance may otherwise be experienced.

Diagrams 2 and 3 show required pump inlet pressure vs. shaft speed.

The F12 motor (type **M** valve plate) sometimes operates as a pump e.g. when used in a propel transmission and the vehicle is going downhill.

Minimum required inlet pressure versus shaft speed is shown in the diagrams.

NOTE: Diagrams 1, 2 and 3 are valid at sea level.

Installation dimensions F11-5 and -10

(CETOP versions)

Dimension	F11-5	F11-10
A	100	125
B max	127	152
C	11	13
D	53	57
E max	96	116
F	65	79
G	5	11
H	47.5	53
K (tol. j6)	18.008/ 17.997	20.009/ 19.996
L min	20.3	23
M max	134	156
N	54	63
P	9	9
Q	13	14
R	40	50
S	30	35
T	5	7
U	88.5	101
V max	84	94
W	38	46
X thread	M6	M6
Y	20.5	22.5
Z (tol. h8)	80.000/ 79.954	100.000/ 99.946
AA	113.5	133
BB	8	8
CC	25	30
DD min	12	12
EE	20	22

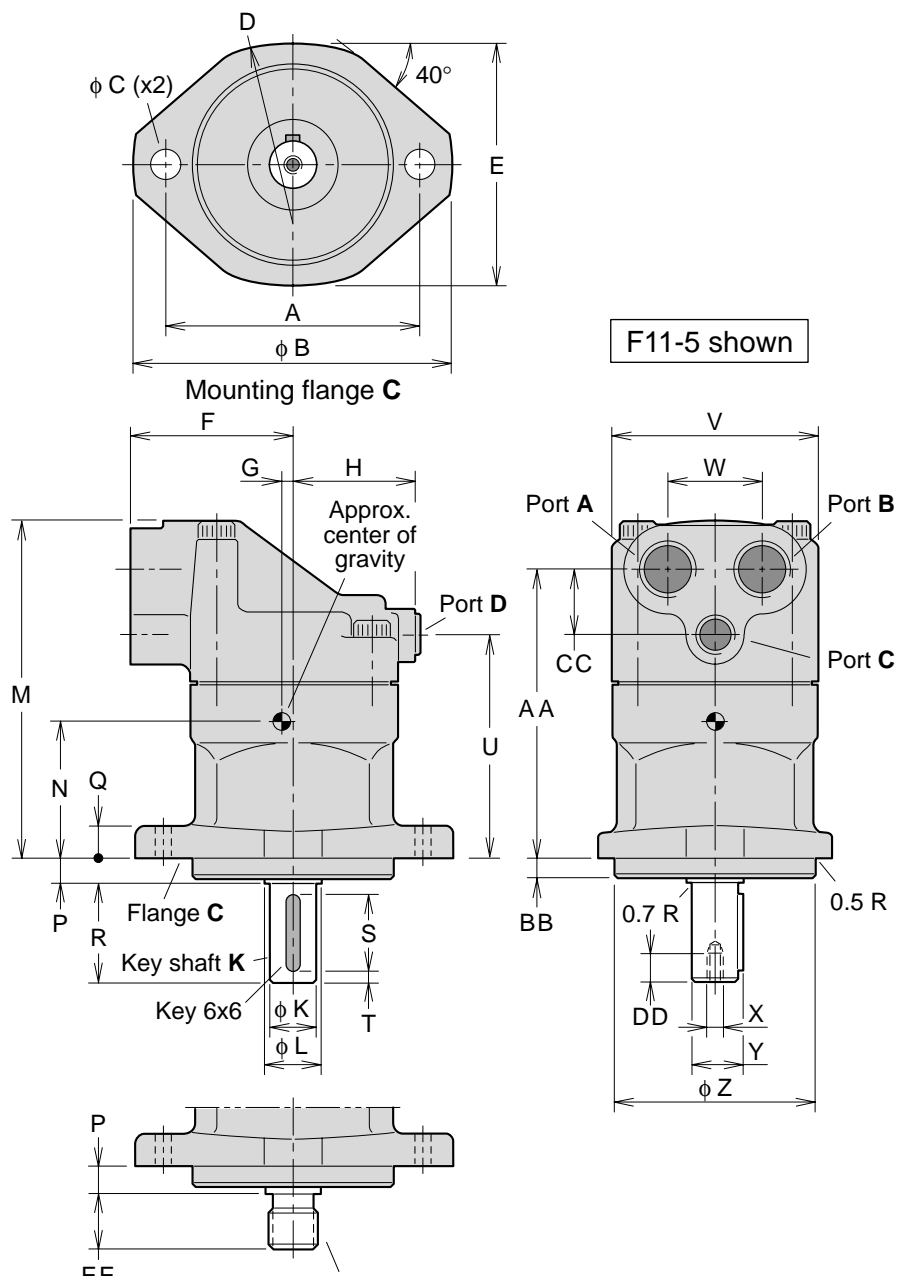

W18x1.25x13x9g (F11-5)
W20x1.25x14x9g (F11-10)
Spline shaft D (DIN 5480)

Ports	F11-5	F11-10
A, B	BSP 1/2"	BSP 3/4"
C, D	BSP 1/4"	BSP 3/8"

Installation dimensions F11-19

(CETOP version)

Dimension	F11-19
A	140
B max	170
C	87
D	14
E	126
F	88
G	63
H	11
K min	28.3
L (tol. h8)	112.000/ 111.946
M max	165
N	25
P	58
Q	42
T	16
U	100
V	10
W max	114
X	54
Y (thread)	M8
Z (tol. j6)	25.009/ 24.996
AA	28
BB	138
CC	23
DD	29
EE min	16
FF	28
Ports	F11-19
A, B	BSP 3/4"
C, D	BSP 3/8"

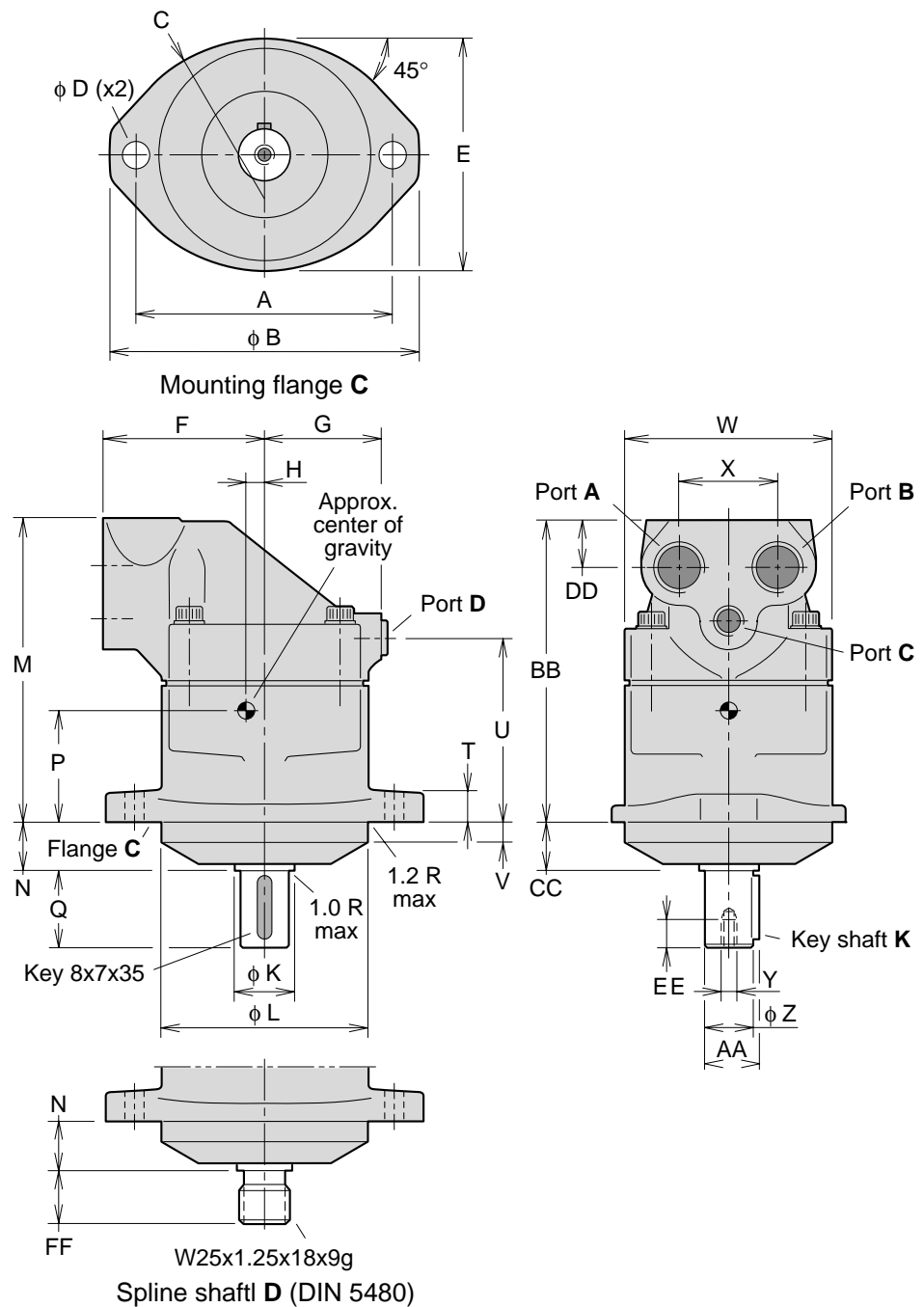

Installation dimensions F11-19

(SAE version)

Dimension	F11-19
A	146.1
B max	176
C	-
D	14.4
E	123
F	88
G	63
H	11
K min	28.3
L	101.60/ 101.55
M max	181
N	8
P	74
Q	38.1
T	17
U	117
V	-
W max	114
X	54
Y*	5/16"-24
Z	25.40/ 25.35
AA	28.1
BB	155
CC	9.6
DD	29
EE min	16
FF	33

* UNC thread

Ports	F11-19
A, B	11/16"-12
C, D	9/16"-18

O-ring ports according to SAE J514d

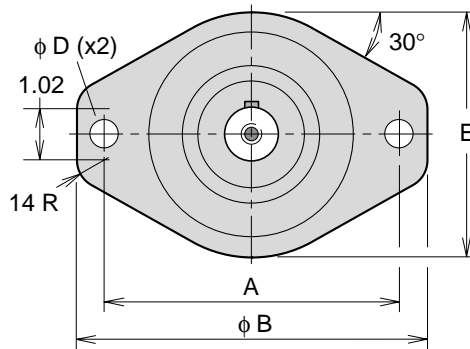

Mounting flange **S**
 SAE 'B' (SAE J744c)

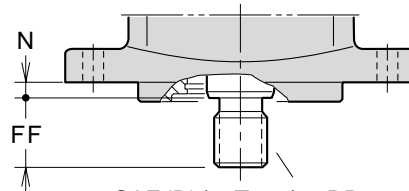
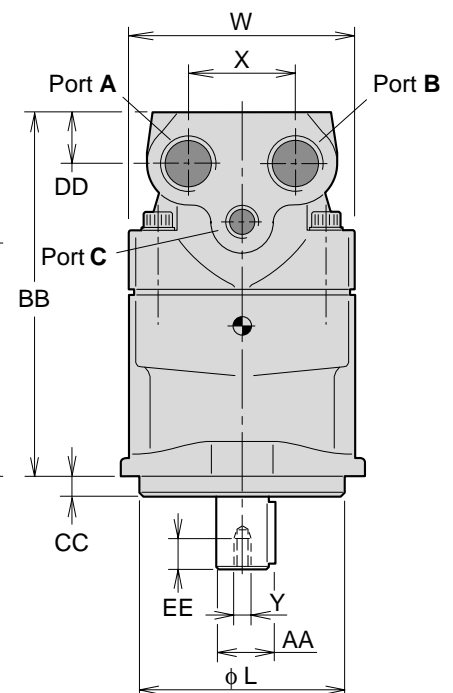
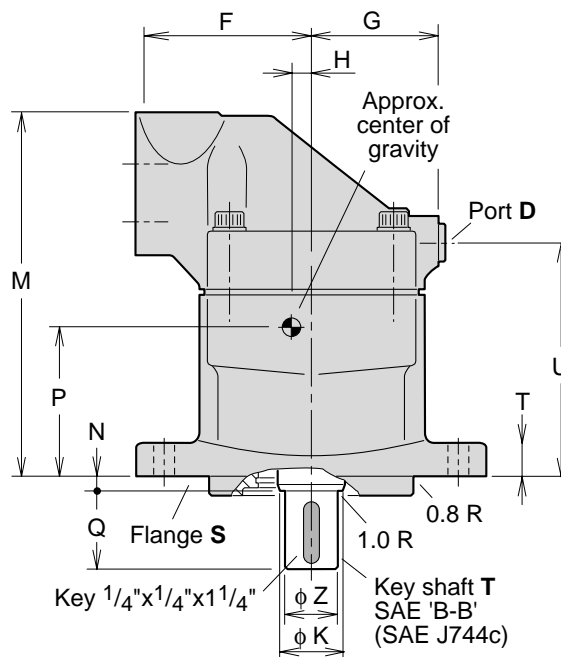

SAE 'B' (13T, 16/32 DP;
 class 1, flat root, side fit)
 Spline shaft **S** (SAE J498b)

Installation dimensions F12-30, -40, -60, -80 and -110

(ISO versions)

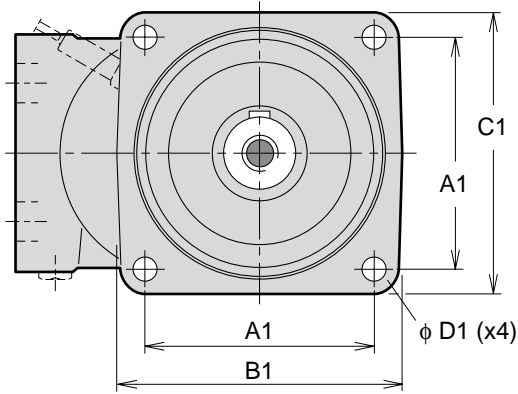

Type I mounting flange
 (ISO 3019/2)

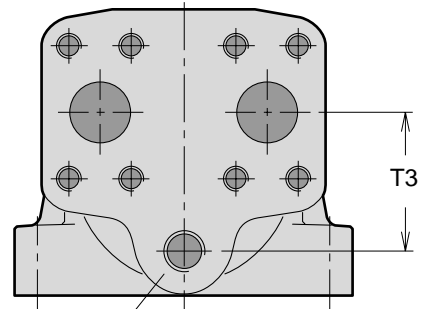

Port E (third drain port)

F12-110 barrel housing
 (ISO/cartridge version)

Shown: F12-80

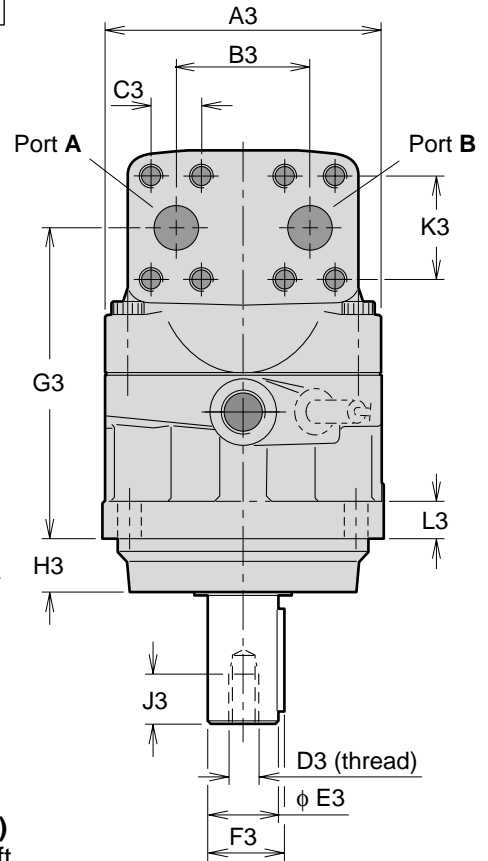
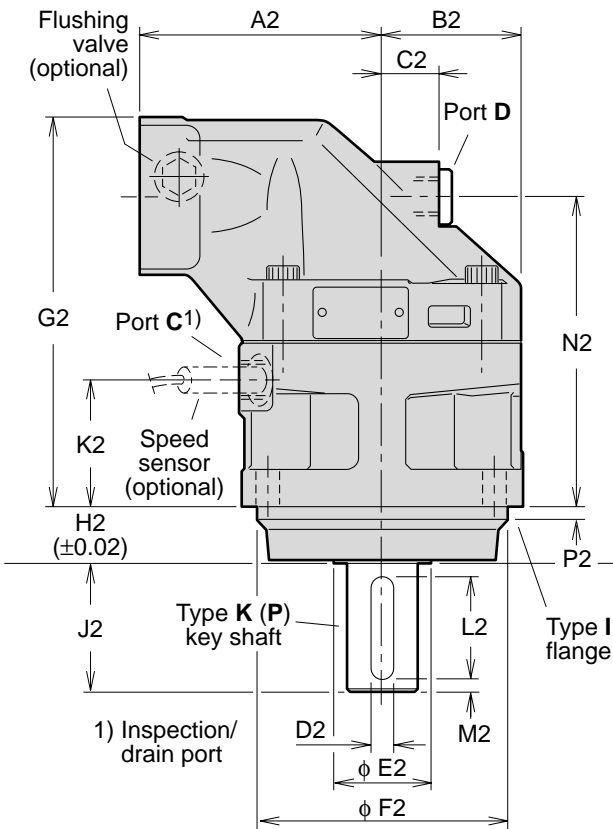

NOTE:
 Type Z has no thread

Type D (Z)
 spline shaft

Dim.	F12-30	F12-40	F12-60	F12-80	F12-110
A1	88.4	113.2	113.2	127.2	141.4
B1	118	146	146	158	180
C1	118	142	144	155	180
D1	11	14	14	13.5	18
A2	100	110	125	135	145
B2	59	65	70	78	85
C2	25	26	22	32	38
D2	8	8	10	12	14
E2	33	42	42	52	58
F2	100	125	125	140	160
G2	172	173	190	216	231
H2	25.5	32.5	32.5	32.5	40.5
J2 ¹⁾	50	60	60	70	82
J2 ²⁾	50	-	-	-	-
K2	55	52	54	70.5	66.5
L2	40	50	50	56	70
M2	5	5	5	7	6
N2	136.5	137	154	172.5	179
P2	8	8	8	8	8
Q2	28	28	33	36	41
R2 ³⁾	35	35	41	45	50
R2 ⁴⁾	43	35	-	41	-
S2 ³⁾	M12 x24	M12 x24	M12 x28	M16 x36	M16 x36
S2 ⁴⁾	-	M12 x24	-	M12 x28	-
A3	122	134	144	155	170
B3	66	66	66	75	83
C3	23.8	23.8	23.8	27.8	31.8
D3	M12	M12	M12	M16	M16
E3	30	30	35	40	45
F3	33	33	38	43	49
G3	136.5	137	154	172.5	179
H3	23.5	30.5	30.5	30.5	38.5
J3	24	24	28	36	36
K3	50.8	50.8	50.8	57.2	66.7
L3	18	20	20	20	22
T3	-	-	-	-	68

- 1) Key shaft type K 3) Spline shaft type D
2) Key shaft type P 4) Spline shaft type Z

Ports	F12-30	F12-40	F12-60	F12-80	F12-110
A, B size	3/4"	3/4"	3/4"	1"	1 1/4"
Screw thread ¹⁾	M10 x20	M10 x20	M10 x20	M12 x20	M14 x26
C thread ²⁾	M22 x1.5	M22 x1.5	M22 x1.5	M22 x1.5	M22 x1.5
D thread ²⁾	M18 x1.5	M18 x1.5	M22 x1.5	M22 x1.5	M22 x1.5
E thread	-	-	-	-	M22 x1.5

A, B: ISO 6162 1) Metric thread x depth in mm

2) Metric thread x pitch in mm.

Spline shaft (DIN 5480)

	Type D (standard)	Type Z (optional)
F12-30	W30x2x14x9g	W25x1.25x18x9g
-40	W32x2x14x9g	W30x2x14x9g
-60	W35x2x16x9g	W32x2x14x9g
-80	W40x2x18x9g	W35x2x16x9g
-110	W45x2x21x9g	-

Key shaft

	Type K (standard)	Type P (optional)
F12-30	φ 30	φ 25
-40	φ 30	-
-60	φ 35	-
-80	φ 40	-
-110	φ 45	-

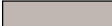
 = Max 350 bar operating pressure

Installation dimensions F12-30, -40, -60, -80 and -110

(Cartridge versions)

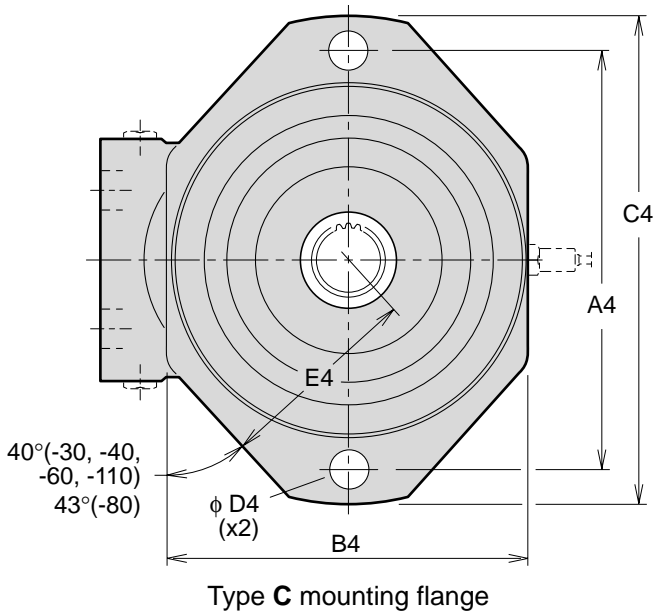

Shown: F12-80

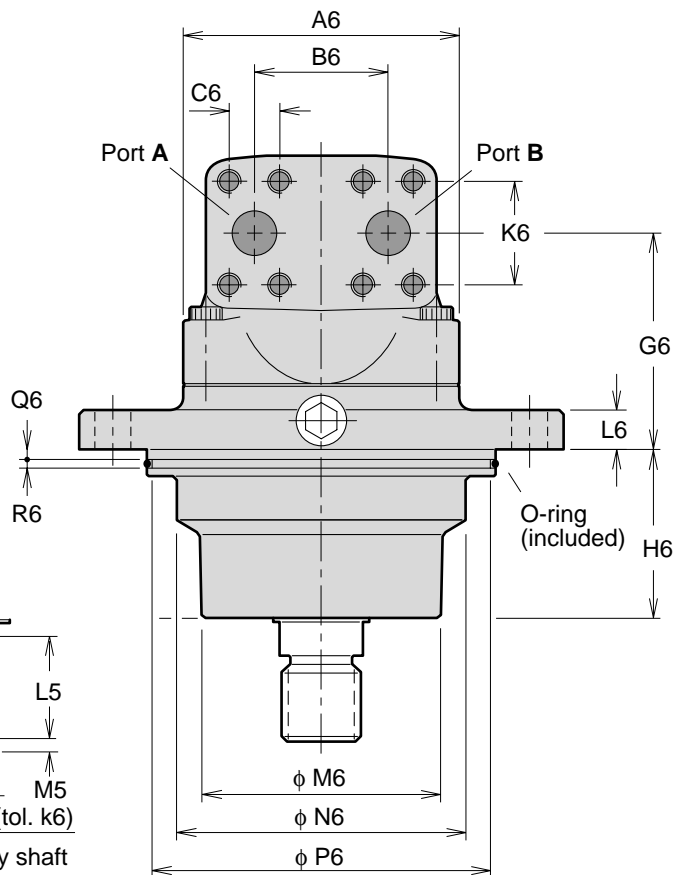
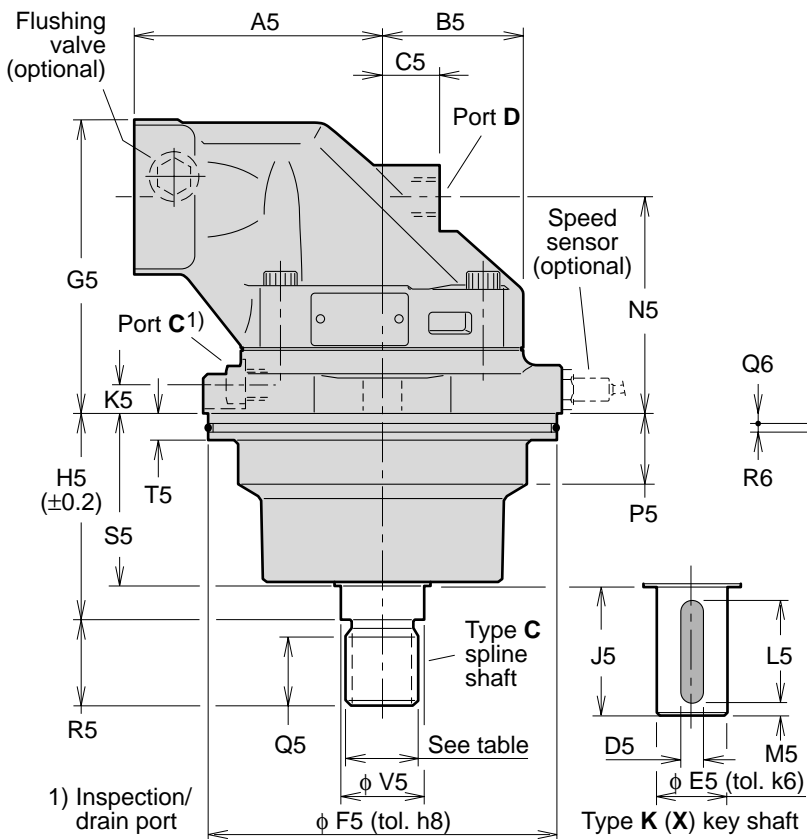
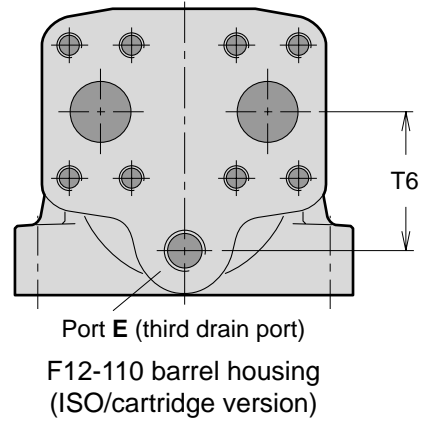

Dim.	F12-30	F12-40	F12-60	F12-80	F12-110
A4	160	200	200	224	250
B4	140	164	164	196	206
C4	188	235	235	260	286
D4	14	18	18	22	22
E4	77	95	95	110	116
A5	100	110	125	135	145
B5	59	65	70	77.5	85
C5	25	26	22	32	38
D5	8	8 ¹⁾ 10 ²⁾	10	12	14
E5	30	30 ¹⁾ 35 ²⁾	35	40	45
F5	135	160	160	190	200
G5	127	133	146	157	175
H5	89	92.3	92.3	110.5	122.8
J5	50	60	60	70	-
K5	14	16	15	15	15
L5	40	50	50	56	-
M5	5	5	5	7	-
N5	91	97	110	114	123
P5	22	30	31	40	40
Q5	28	28	28	37	37
R5	35	35	35	45	45
S5	70.5	72	76	91	95.7
T5	15	15	15	15	15
V5	32	35	35	45	45
A6	122	134	144	155	170
B6	66	66	66	75	83
C6	23.8	23.8	23.8	27.8	31.8
G6	91.5	97	110	114	123
H6	69.5	71	74	89.5	93.7
K6	50.8	50.8	50.8	57.2	66.7
L6	16	18	18	20	20
M6	92	115	115	130	140
N6	110	127	135	154	160
P6	128.2	153.2	153.2	183.2	193.2
Q6	5	5	5	5	5
R6	5	5	5	5	5
T6	-	-	-	-	68

- 1) Key shaft type **K**
- 2) Key shaft type **X** (opt.).

Ports	F12-30	F12-40	F12-60	F12-80	F12-110
A, B size	3/4"	3/4"	3/4"	1"	1 1/4"
Screw thread	M10 x20	M10 x20	M10 x20	M12 x22	M14 x26
C thread	M14 x1.5	M14 x1.5	M14 x1.5	M14 x1.5	M14 x1.5
D, E thread	M18 x1.5	M18 x1.5	M22 x1.5	M22 x1.5	M22 x1.5

A, B: ISO 6162

Spline shaft (DIN 5480)
Type **C** (standard)

F12-30	W30x2x14x9g
-40	W30x2x14x9g
-60	W30x2x14x9g
-80	W40x2x18x9g
-110	W40x2x18x9g

Key shaft
Type **K** (std) Type **X** (opt.)

F12-30	φ 30	-
-40	-	φ 35
-60	φ 35	-
-80	φ 40	-

O-ring dimensions

F12-30	127x4
-40	150x4
-60	150x4
-80	180x4
-110	190x4

Installation dimensions F12-30, -40, -60, -80 and -110

(SAE versions with 4 bolt flange)

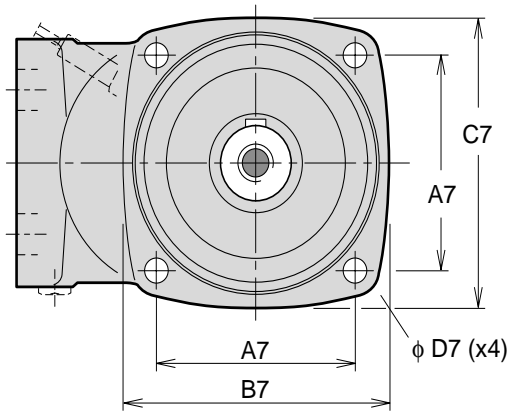

Type S (SAE 4 bolt) mounting flange

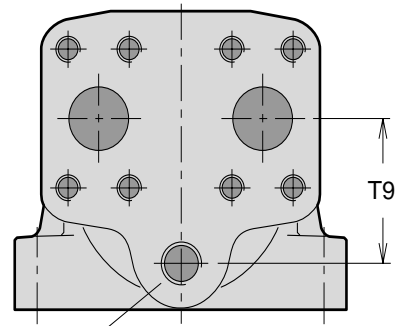

Port E (third drain port)
 F12-110 barrel housing
 (SAE version)

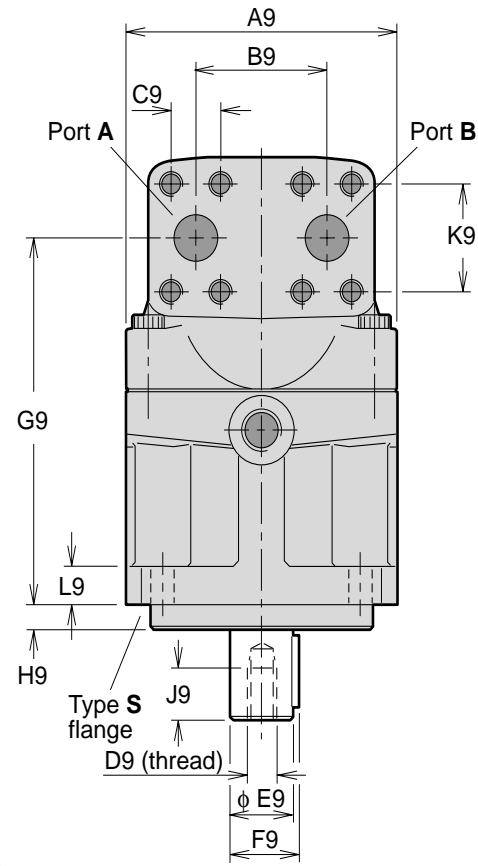
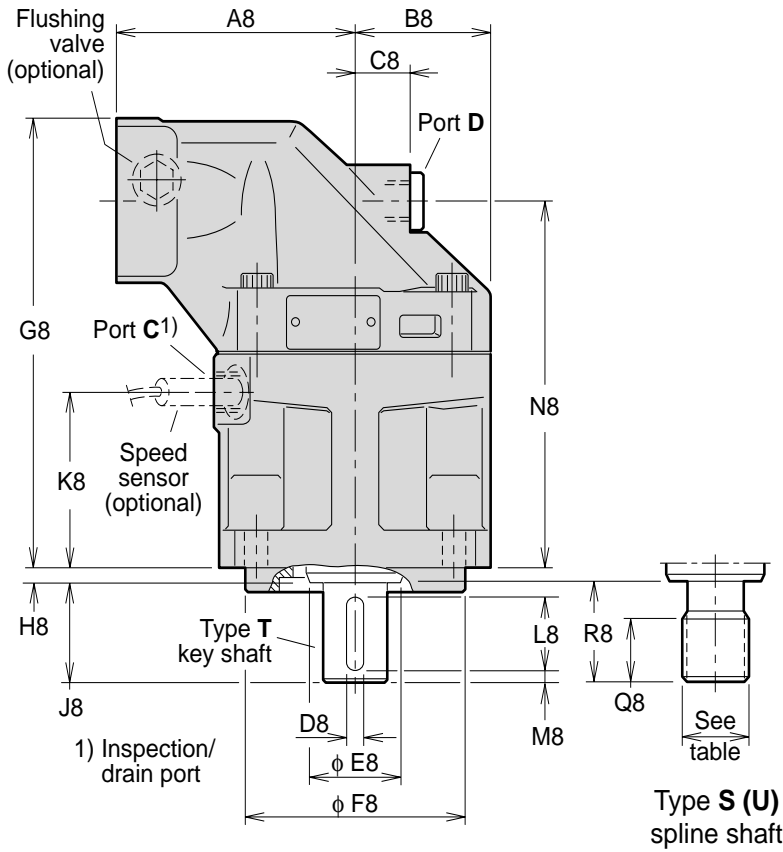

Shown: F12-80 with 4 bolt flange

Dim.	F12-30	F12-40	F12-60	F12-80	F12-110
A7	89.8	114.5	114.5	114.5	161.6
B7	118	148	148	155	204
C7	118	144	144	155	200
D7	14	14	14	14	21
A8	100	110	125	135	145
B8	59	65	70	77.5	85
C8	25	26	22	32	38
D8	6.35	7.94	7.94	9.53	11.1
E8	33	42	42	52	57.5
F8	101.60/ 101.55	127.00/ 126.94	127.00/ 126.94	127.00/ 126.94	152.40/ 152.34
G8	189.5	197	214	240	264
H8	8	8	8	8	8
J8	38	48	48	54	67
K8	72	76	79	95	99
L8	31.8	38.1	38.1	44.5	54.1
M8	2.5	4	4	4	7.5
N8	153.5	161	178.3	197.1	212
Q8 ¹⁾	23	23	23	25	34
Q8 ²⁾	-	-	-	23	-
R8 ¹⁾	33	48	48	54	66.7
R8 ²⁾	-	-	-	48	-
A9	122	134	144	155	170
B9	66	66	66	75	83
C9	23.8	23.8	23.8	27.8	31.8
D9*	5/16"-24	3/8"-24	3/8"-24	1/2"-20	5/8"-18
E9	25.40/ 25.35	31.75/ 31.70	31.75/ 31.70	38.10/ 38.05	44.45/ 44.40
F9	28.2	35.3	35.3	42.3	49.4
G9	153.8	161	178.3	197.1	212
H9	9.7	12.7	12.7	12.7	12.7
J9	16	19	19	26	32
K9	50.8	50.8	50.8	57.2	66.7
L9	18	20	20	20	22
T9	-	-	-	-	68

* UNF-2B thread

- 1) Spline shaft type **S**
2) " " " **U**

Ports	F12-30	F12-40	F12-60	F12-80	F12-110
A, B size	3/4"	3/4"	3/4"	1"	1 1/4"
Screw thread ³⁾	3/8"-16 x22	3/8"-16 x20	3/8"-16 x22	7/16"-14 x27	1/2"-13 x25
C thread	7/8"-14	7/8"-14	7/8"-14	7/8"-14	1 1/16"-12
D thread	3/4"-16	3/4"-16	7/8"-14	7/8"-14	1 1/16"-12
E thread	-	-	-	-	1 1/16"-12

A, B: ISO 6162

C, D, E: O-ring boss (SAE J514)

3) UN thread x depth in mm.

Mounting flange (SAE J744)

	S (standard)	X (optional)
F12-30	SAE 'B', 4 bolt	-
-40	SAE 'C', "	-
-60	SAE 'C', "	-
-80	SAE 'C', "	SAE 'D', 4 bolt
-110	SAE 'D', "	-

Spline shaft (SAE J498b)

	S (standard)	U (opt.)	X (optional)
F12-30	SAE 'B' 13T, 16/32 DP	-	-
-40	SAE 'C' 14T, 12/24 DP	-	-
-60	SAE 'C' 14T, 12/24 DP	-	-
-80	SAE 'C-C' 17T, 12/24 DP	SAE 'C' 14T,12/24DP	SAE 'D' 13T, 8/16 DP
-110	SAE 'D' 13T, 8/16 DP	-	-

 = Max 350 bar operating pressure.

Key shaft (SAE J744)

	S (standard)	X (optional)
F12-30	SAE 'B-B' (φ 25.4 mm/1")	-
-40	SAE 'C' (φ 31.75 mm/1 1/4")	-
-60	SAE 'C' (φ 31.75 mm/1 1/4")	-
-80	SAE 'C-C' (φ 38.1 mm/1 1/2")	SAE 'D' (φ 44.45 mm/1 3/4")
-110	SAE 'D' (φ 44.45 mm/1 3/4")	-

Installation dimensions F12-30, -40, and -60
 (SAE versions with 2 bolt flange)

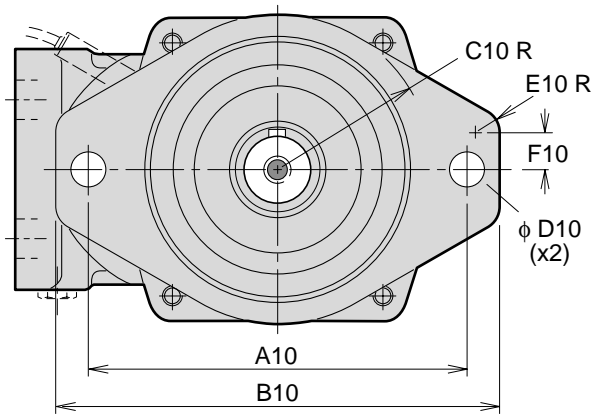

Type T (SAE 2 bolt) mounting flange

Shown: F12-60 with 2 bolt flange

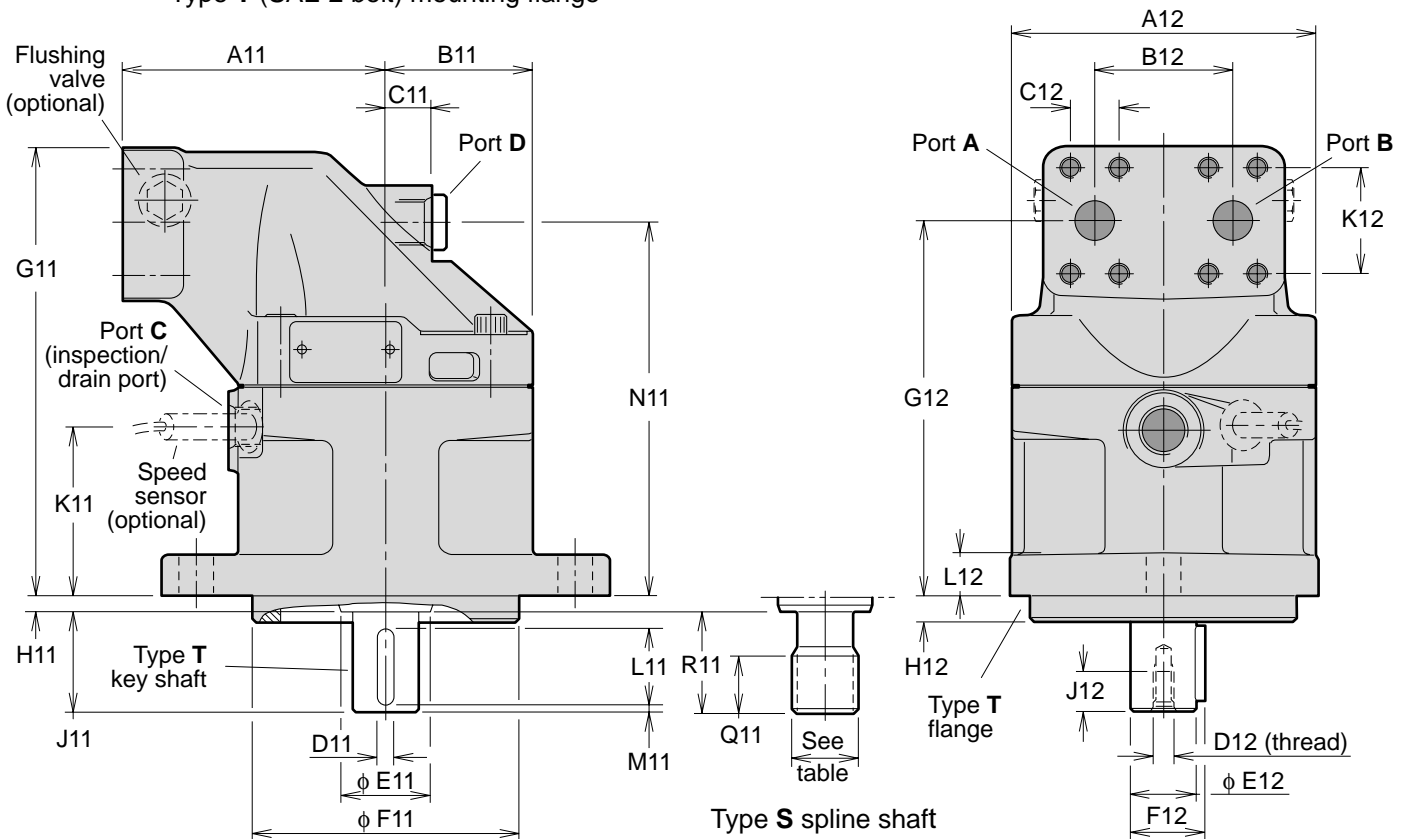

Dim.	F12-30	F12-40	F12-60
A10	146	181	181
B10	176	215	215
C10	63	74	74
D10	14.4	17.5	17.5
E10	10	16	16
F10	10	15.5	15.5
A11	100	110	125
B11	59	65	70
C11	25	26	22
D11	6.35	7.94	7.94
E11	33	42	42
F11	101.60/ 101.55	127.00/ 126.95	127.00/ 126.95
G11	189.5	197	214
H11	8	8	8
J11	38	48	48
K11	71	77	81.5
L11	31.8	38.1	38.1
M11	2.5	4	4
N11	154	161	178.5
Q11	26	27	27
R11	33	48	48
A12	122	134	144
B12	66	66	66
C12	23.8	23.8	23.8
D12 ¹⁾	5/16"-24	3/8"-24	3/8"-24
E12	25.40/ 25.35	31.75/ 31.70	31.75/ 31.70
F12	28.2	35.2	35.2
G12	154	161	178.5
H12	9.7	12.7	12.7
J12	16	19	19
K12	50.8	50.8	50.8
L12	18	20	20

1) UNF-2B thread

Ports	F12-30	F12-40	F12-60
A, B size	19 (3/4")	19 (3/4")	19 (3/4")
Screw thread ²⁾	3/8"-16 x22	3/8"-16 x20	3/8"-16 x22
C thread	3/4"-16	3/4"-16	7/8"-14
D thread	3/4"-16	3/4"-16	7/8"-14

A, B (main ports): SAE J518c (6000 psi)
C, D (drain ports): O-ring boss (SAE J514)
2) UN thread

Mounting flange T (SAE J744)

F12-30	SAE 'B', 2 bolt
-40	SAE 'C', 2 bolt
-60	SAE 'C', 2 bolt

Spline shaft S (SAE J498b)

F12-30	SAE 'B' 13 T; 16/32 DP
-40	SAE 'C' 14 T; 12/24 DP
-60	SAE 'C' 14 T; 12/24 DP

Key shaft T (SAE J744)

F12-30	SAE 'B-B' φ 25.4 mm/1"
-40	SAE 'C' φ 31.75 mm/1 1/4"
-60	SAE 'C' φ 31.75 mm/1 1/4"

Installation dimensions F11-150

(CETOP version)

Dim.	F11-150
A max	236
B	236
C	250
D	22
E	172
F	118
G	18
J min	57
K (tol h8)	200.000/ 199.928
L	307
M	109
Q	25
R	159
S max	222
T	101
U	36.5
V (tol. k6)	50.018/ 50.002
W	53.5
X	250
Y	50
Z	85
AA	46
BB	82
CC	30
DD	M16 x35
EE	79.4
FF	44

Ports	Type F
A, B	1 1/2" *
C, D	BSP 3/4"

* 6000 psi flange (SAE J581c)

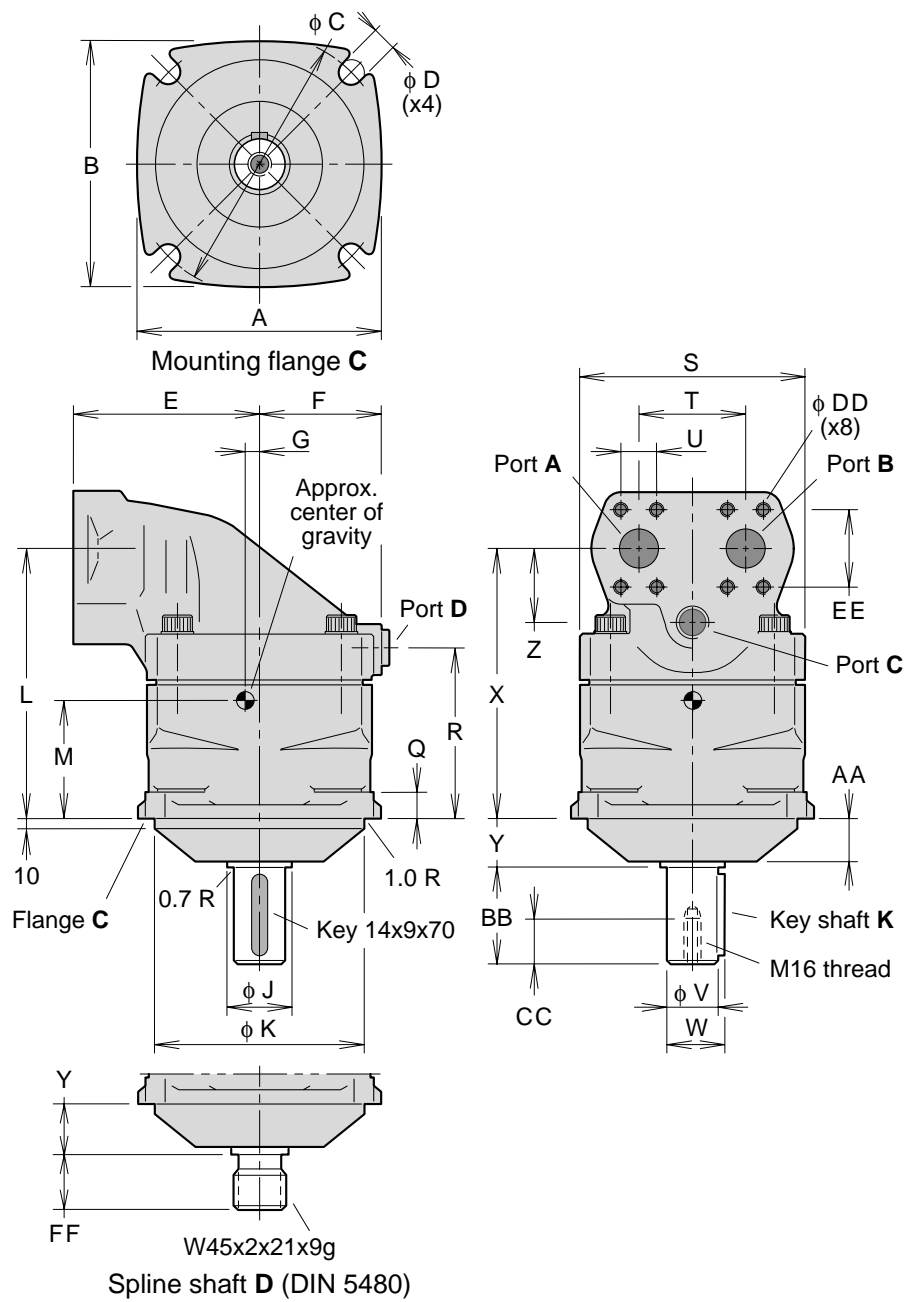

Installation dimensions F11-150

(SAE version)

Dim.	F11-150
A max	214
B	192
C	161.6
D	21
E	172
F	118
G	18
J min	57
K	152.40/ 152.35
L	355
M	157
Q	24
R	206
S max	222
T	101
U	36.5
V	44.45/ 44.40
W	49.3
X	297
Y	8
Z	85
AA	12.7
BB	66.7
CC	30
DD	M16x35
EE	79.4
FF	66.7

Ports	Type F
A, B	1 1/2" *
C, D	BSP 3/4"

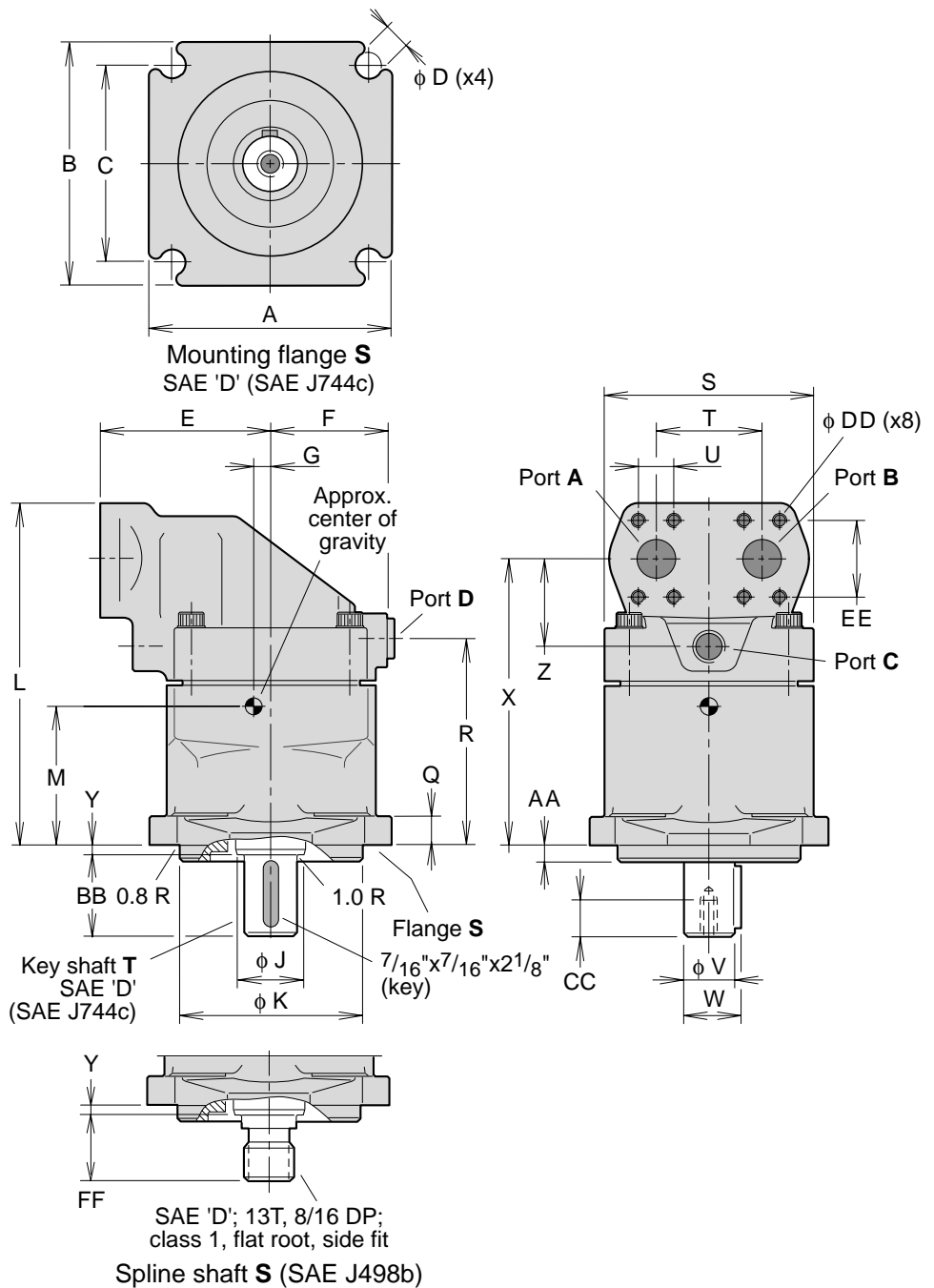

* 6000 psi flange (SAE J581c)

Installation dimensions F11-250

(SAE version)

Dimension	F11-250
A	161.6
B max	206
C max	206
D	161.6
E	21
F	197
G	118
H	27
J	79
L	50.018/ 50.002
M min	57
P	395
Q	180
R	7.9
S	82
W	24
X	216
Y	232
Z	101
AA	36.5
BB	53.5
CC	152.40/ 152.35
DD	336
EE	141
FF	12.7
GG	79.38
HH	35
JJ	66.7
Ports	Type F
A, B	1 1/2" *
C, D	BSP 3/4"

* 6000 psi flange (SAE J518c)

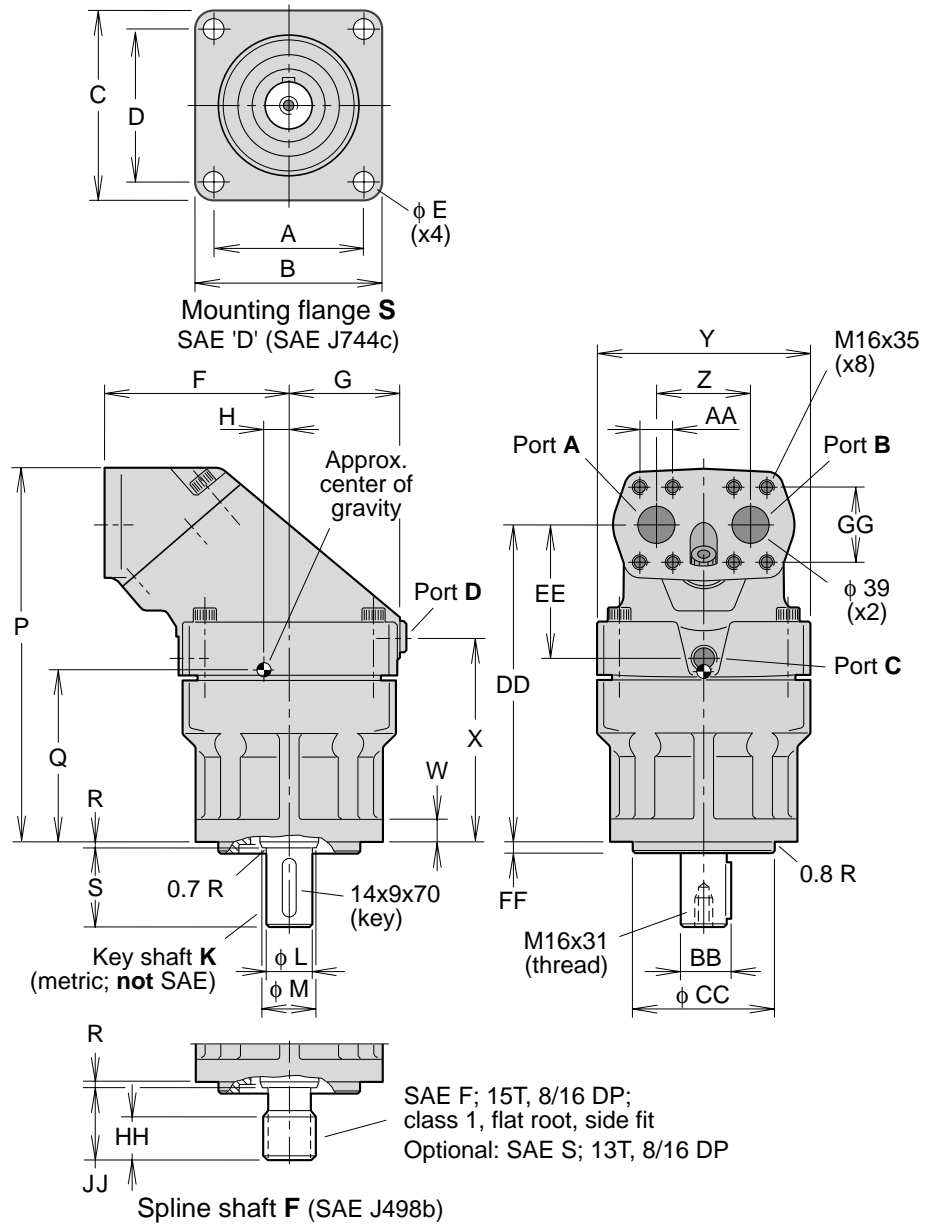

F11 saw motors

Series F11 motors have proven extremely reliable in demanding applications such as bar (chain) saws. Primarily due to the 40° bent-axis design, spherical pistons (with laminated piston rings) and gear synchronization, very high speeds are permissible. Not even low temperatures at start-up affect reliability.

To further enhance the saw function and, at the same time, reduce weight, cost and installation dimensions, a specific saw motor has been developed (frame sizes -10 and -19; refer to the illustration to the right) which is specifically dedicated to bar saws. The motor allows the saw bar bearings to be mounted directly on the motor housing, and the spur gear installs on the motor shaft without any additional bearings.

For more detailed information (available versions, ordering codes, installation dimensions, etc.), refer to 'F11 Saw Motors' (catalog 9129 8245-02).

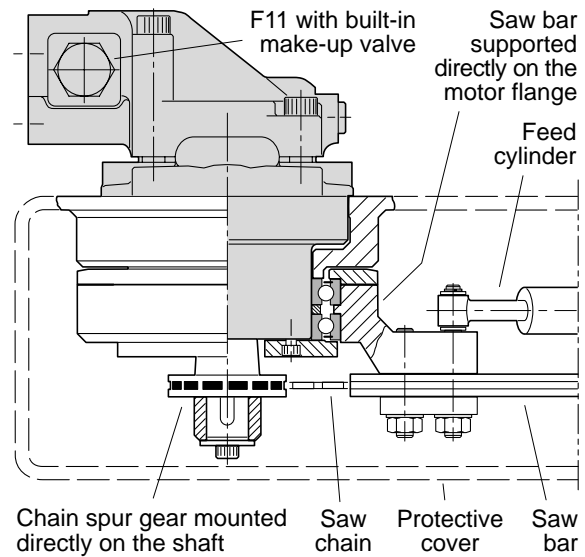

Chain saw installation (example; F11-10 shown)

F11 fan motors

Frame sizes -10 and -19 are also available as 'fan motors' with a built-in check valve (refer to the schematic below) and CETOP mounting flange. Just like the saw motor, the fan motor can be operated at very high speeds without reliability problems. The fan is usually installed directly on the motor shaft without additional bearing support.

Additional information (available versions, ordering codes, installation dimensions, etc.) is available in publication 'F11 Fan Motors' (catalog 9129 8247-02).

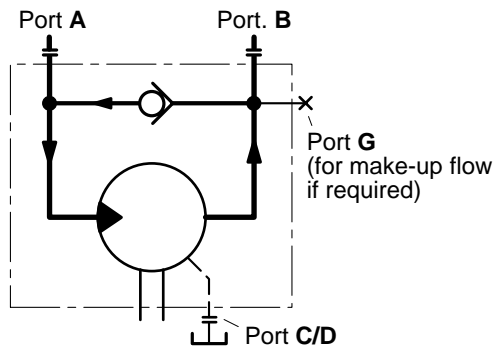

Fan motor schematic (left hand rotation shown).

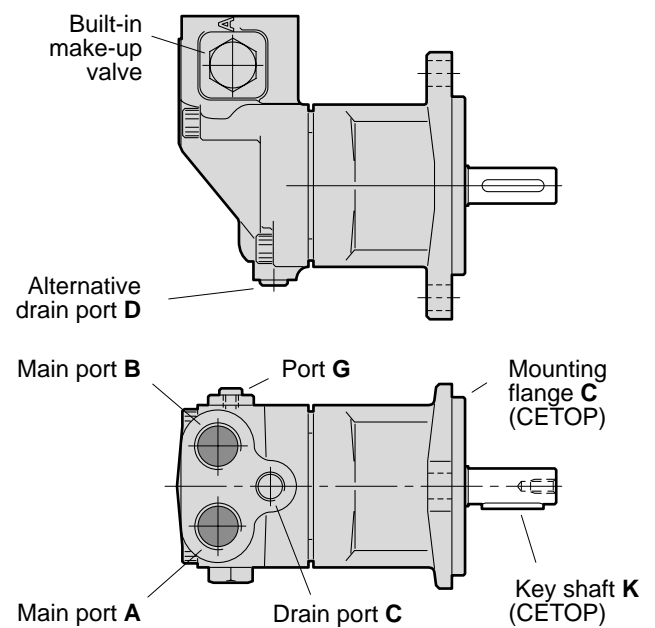

Fan motor (F11-10 shown).

F12 integrated flushing valve

(F12-30, -40, -60 and -80)

Series F12 (except F12-110; refer to the FV13 flushing valve block below) is available with an integrated flushing valve which provides the rotating parts with an additional cooling flow, required when operating at high speeds and power levels.

In a hydrostatic transmission, the valve also ensures that part of the main circuit fluid is being removed and replaced by cool, filtered fluid from the charge pump.

The flow is limited by a suitably sized nozzle that installes below a plug in the motor port flange.

NOTE: Ordering code, available nozzles and other information is provided in publication 'Flushing Valves for F12 Motors' (catalog 9129 8237-02).

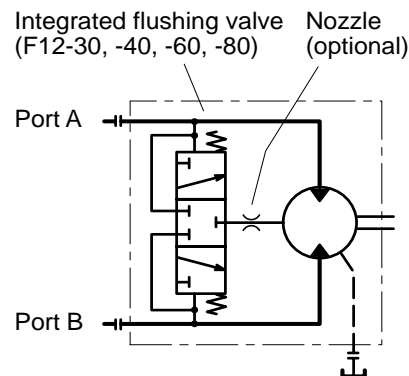
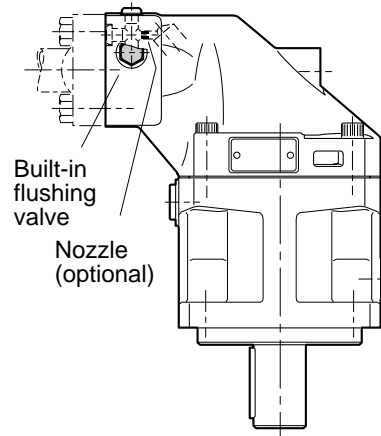

F12 accessory valve blocks

Type FV13 flushing valve (for F12-110)

A separate flushing valve block is available for the F12-110. It has the same function as the integrated valve for the other F12 frame sizes (above).

The valve block mounts between the motor port flange and the split flanges as shown to the right.

An optional nozzle can be installed in the valve block drain port.

Ordering code: FV13

NOTE: Additional information is available in publication 'Flushing Valves for F12 Motors' (catalog 9129 8237-02).

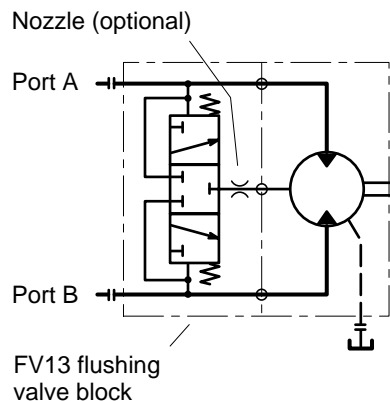
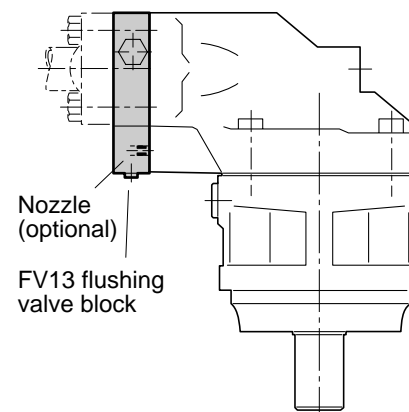

Type BT brake valve

When a motor (in an open loop system) is used in a hydrostatic vehicle transmission, the motor may operate faster than what corresponds to the available pump flow (e.g. in a steep downhill); this can lead to motor cavitation and loss of braking power.

The BT brake valve prevents cavitation by throttling the return flow from the motor as soon as the pressure level in the inlet port decreases to approximately 35 bar. At the same time, motor braking is provided when the pump flow decreases or is shut off.

The BT brake valve can be supplied with various optional functions such as a mechanical brake release valve and a flushing valve.

The valve block is very compact and installs between the motor port flange and the split flanges (refer to the illustration).

The BT valve block is available in two sizes:

- BT21 (3/4") for F12-30, -40, -60
- BT22 (1") for F12-80

NOTE: Detailed information on the BT valve is provided in publication 'BT brake valve for F12/T12 motors' (catalogue 9129 8229-02).

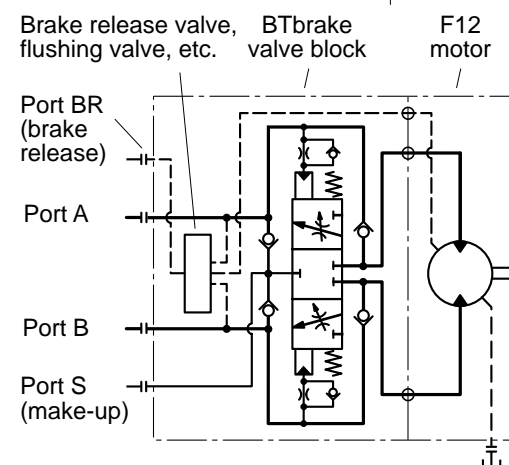
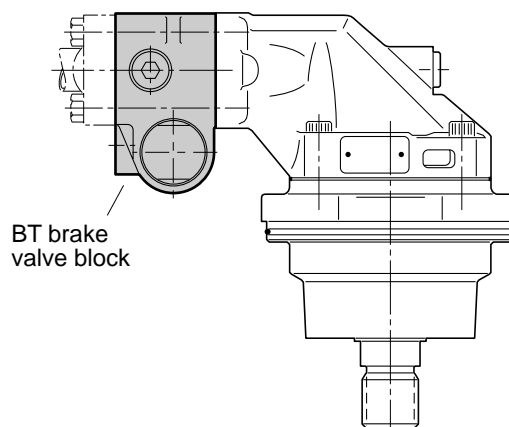

Type SR pressure relief/make-up valve

The SR pressure relief/make-up valve block for series F12 motors is designed to protect the motor from high pressure spikes as well as provide an excellent make-up function to help prevent motor cavitation (when port G is pressurized).

The valve block mounts between the motor port flange and the split flanges (as shown to the right).

The SR block is available in three sizes:

- SR11 (3/4") for F12-30, -40, -60
- SR12 (1") for F12-80
- SR13 (1 1/4") for F12-110

NOTE: - For additional information such as pressure settings and installation dimensions, refer to publication 'SR pressure relief/make-up valve' (catalog 9129 8226-02).

- To obtain a combined cross-over relief/make-up and flushing function on the F12-110, the SR13 and FV13 valve blocks can be stacked (with the flushing valve block mounted next to the motor).

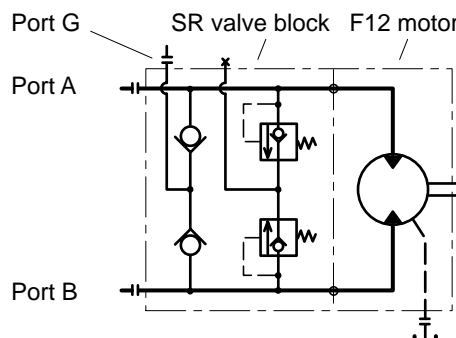
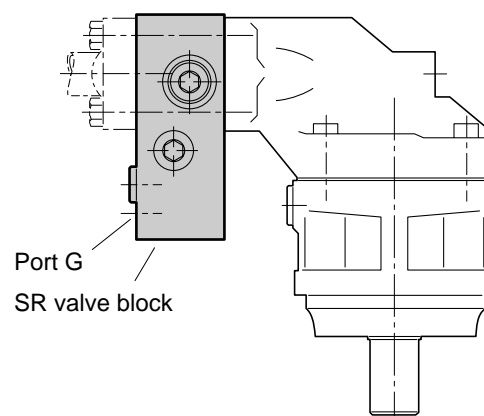

Type SV pressure relief valve

The SV pressure relief valve for series F12 motors protects the motor and the corresponding main hydraulic lines from pressure spikes. Like the SR valve block (page 27), it has integrated cartridge type pressure relief valves and mounts between the motor port flange and the split flanges as shown to the right.

The design of the relief valves permits a limited make-up flow (when port L is pressurized).

The SV valve block is available in three sizes:

- SV11 (3/4") for F12-30, -40, -60
- SV12 (1") for F12-80
- SV13 (1 1/4") for F12-110

NOTE: - Detailed information on available pressure settings, installation dimensions, etc. is provided in publication 'SV pressure relief valve' (catalog 9129 8225-02).

- On the F12-110, the FV13 flushing valve block (page 26) can be mounted between the SV13 block and the motor port flange to obtain a combined pressure relief and flushing function.

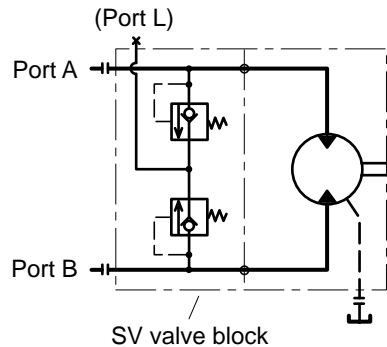
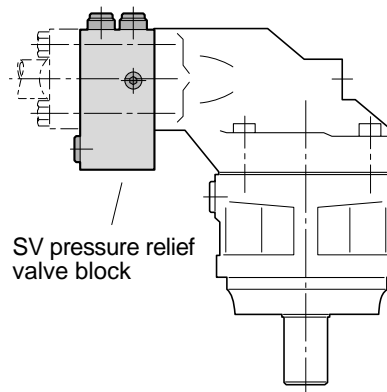

F12 speed sensor

A speed sensor kit is available for series F12. A ferromagnetic differential (Hall-effect) sensor installs in a separate, threaded hole in the F12 bearing housing.

The speed sensor is directed towards the F12 ring gear and outputs a square wave signal within a frequency range of 5 Hz to 20 kHz. The number of pulses per shaft rev is 35 which, at 5 Hz, corresponds to approx. 9 rpm.

The speed sensor is shipped as a separate kit which includes a seal nut.

NOTE: - The motor bearing housing must be prepared for the speed pick-up; refer to the F12 ordering codes (page 7).

- Additional information is provided in MI 146 (Marketing Information) available from Parker Hannifin (Mobile Controls Div.).
- The speed sensor is also shown in the illustrations on pages 14, 16, 18 and 20.

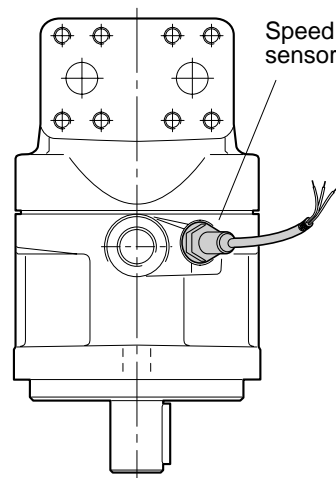

F12 main port suction fittings

Suction fittings

To minimize the risk for cavitation when operating the F12 as a pump, we recommend using our suction fittings; all take 2" hoses.

Part no.	SAE size	For	Max speed [rpm] ¹⁾	L [mm]
379 4070	3/4"	F12-30	2850 ²⁾	100
		F12-40	2650 ²⁾	
		F12-60	2000 ³⁾	
370 4095	1"	F12-80	1500 ³⁾	100
370 3916	1 1/4"	F12-110	1100 ³⁾	102

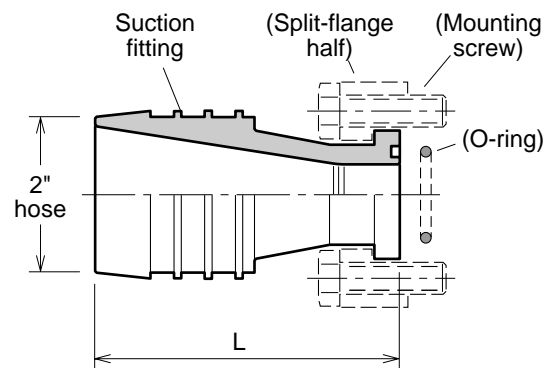

NOTE: 1) Shaft speeds shown are theoretical and may have to be decreased because of long hoses and/or other unfavourable inlet conditions.

2) Selfpriming speed

3) Below selfpriming speed

The suction fittings are designed for use with standard SAE or metric split-flange halves as shown. O-ring and mounting screw sizes are listed below.

SAE size	O-ring dimension	Screw size	
		SAE	Metric
3/4"	30.0x3.53	3/8"-16x1.50	M10x35
1"	32.9x3.53	7/16"-14x1.50	M12x40
1 1/4"	37.7x3.53	1/2"-13x1.75	M14x45

Suction fitting kits

Suction fitting kits are available for the F12 ISO and Cartridge versions. A kit consists of a suction fitting (shown above), two split-flange halves, an O-ring and four mounting screws.

Part no.	SAE size	For	Screw size
379 4421	3/4"	F12-30/-40/-60	M10x35
370 4098	1"	F12-80	M12x40
370 3926	1 1/4"	F12-110	M14x45

Split-flange kits

Separate metric split-flange kits, consisting of two split-flange halves and four mounting screws for use on the F12 ISO and cartridge versions, are also available.

Part no.	SAE size	For	Screw size
379 4405	3/4"	F12-30/-40/-60	M10x35
370 4329	1"	F12-80	M12x40
370 4330	1 1/4"	F12-110	M14x45

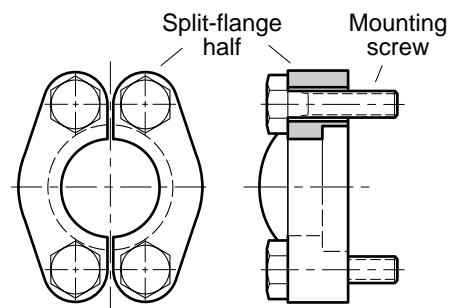

Installation information

Direction of rotation

The M and H versions of series F11, and the M version of series F12, are bi-directional.

The L and R pump versions are uni-directional, allowing higher selfpriming speeds (refer to page 10).

The illustration to the right shows direction of flow versus shaft rotation. In a motor application, the shaft turns clockwise when port **B** (black arrow) is pressurized, and counter clockwise when port **A** (open arrow) is pressurized.

In a pump application where the shaft turns clockwise, port B is the inlet port and should be connected to tank; when the shaft turns counter clockwise, port A is the inlet port.

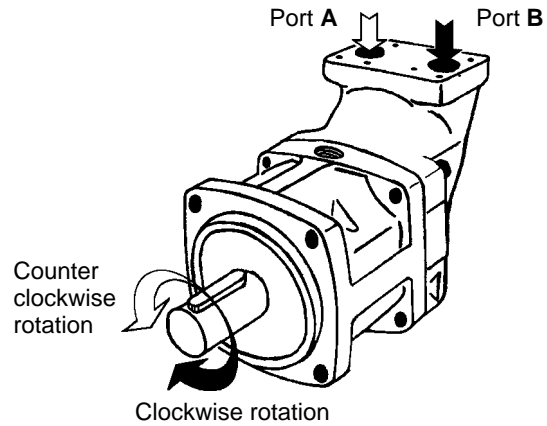

Filtration

To obtain the highest service life of the F11/F12, the fluid cleanliness should meet or exceed ISO code 18/13 (ISO 4406).

During normal operating conditions, a 10 µm (absolute) filter is recommended.

Case pressure

The tables below show the highest recommended case pressure as a function of shaft speed.

'Nominal' shaft seal life can be expected at a certain speed and the corresponding max case pressure. Seal life will be shorter, however, at unfavourable operating conditions (high temperature, low oil viscosity, contaminated oil).

NOTE:

When operating the F11/F12 as a pump above the selfpriming speed (valid for both the pump and motor versions), the inlet must be sufficiently pressurized. Increased noise and deteriorating performance may otherwise be experienced.

For further information refer to 'Selfpriming speed and required inlet pressure' on page 10.

Series F11

Max case pressure [bar] versus shaft speed [rpm]

Speed Shaft seal	1500		3000		4000		5000		6000		8000		10000		12000	
	H	N/E	H	N/E	H	N/E	H	N/E	H	N/E	H	N/E	H	N/E	H	N/E
F11-5	20	2.2	13	1.9	10	1.6	8	1.3	6.5	0.9	5	0.5	4	0.2	3	0
F11-10	20	2.2	11.5	1.8	8.5	1.2	7	1	5.5	0.7	4	0.3	3.5	-	-	-
F11-19	19	2.2	9.5	1.4	7	0.9	5.5	0.6	4.5	0.4	3.5	-	-	-	-	-
F11-150	9.5	2.2	4.5	0.6	-	-	-	-	-	-	-	-	-	-	-	-
F11-250	9.5	-	4.5	-	-	-	-	-	-	-	-	-	-	-	-	-

Max recommended case pressure versus shaft speed - F11 seal types **H**, and **N** or **E**.

Series F12

Max case pressure [bar] vs. shaft speed [rpm]

Speed Shaft seal	1500		3000		4000		5000		6000	
	H/V	N	H/V	N	H/V	N	H/V	N	H/V	N
F12-30	14	2.2	7	1.4	5.5	0.9	4.5	0.6	3.5	0.2
F12-40	12	2.2	6	1.2	4.5	0.7	3.5	0.4	-	-
F12-60	12	2.2	6	1.2	4.5	0.7	3.5	0.4	-	-
F12-80	10	2.2	5	0.8	4	0.4	-	-	-	-
F12-110	9.5	2.2	4.5	0.6	-	-	-	-	-	-

Max recommended case pressure versus shaft speed - F12 seal types **H** or **V**, and **N** (optional)

Operating temperature

The following temperatures should not be exceeded (type **H** and **N** shaft seals):

System fluid: 70 °C

Drain fluid: 90 °C.

FPM shaft seals (F11 type **E**, F12 type **V**) can be used to 115 °C drain fluid temperature.

NOTE: The temperature should be measured at the utilized drain port.

Continuous operation may require case flushing in order to meet the viscosity and temperature limitations.

The following table shows operating speeds, above which flushing is usually required, as well as suggested flow through the case.

Series F11

Frame size	Speed [rpm]	Flow [l/min]
F11-5	5500	1-2
F11-10	4500	2-3
F11-19	4000	2-4
F11-150	2200	10-20
F11-250	1800	12-22

Series F12

Frame size	Speed [rpm]	Flow [l/min]
F12-30	3500	4-8
F12-40	3000	5-10
F12-60	3000	7-14
F12-80	2500	8-16
F12-110	2300	9-18

Hydraulic fluids

Ratings and performance data for series F11/F12 are based on operating with good quality, contamination-free, petroleum-based fluids.

Hydraulic fluids type HLP (DIN 51524), automatic transmission fluids type A, or API CD engine oils can be used.

At operating temperature, the viscosity (of the drain fluid) should normally be kept above 10 mm²/s [cSt].

At start-up, the viscosity should not exceed 1 000 mm²/s.

The ideal operating range is 15 to 30 mm²/s.

Fire resistant fluids (when used under modified operating conditions) and synthetic fluids may also be suitable.

For additional information, refer to the following publications (available from Parker Hannifin, Mobile Controls Div.):

MI 180 - Hydraulic fluid specifications

MI 189 - Fire resistant fluids.

Case drain connections

Series F11/F12 have two drain ports, **C** and **D**, while F12-110 has an additional port, **E**.

The uppermost drain port (such as port C in the illustration below) should always be utilized.

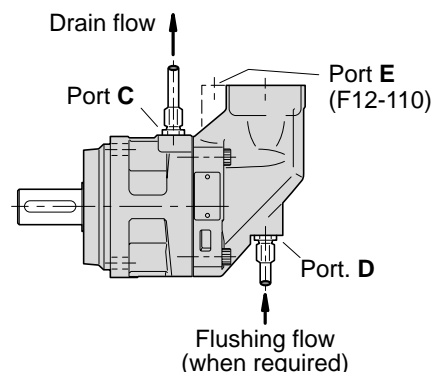

In mounting positions such as 'shaft up' (below) a spring loaded check valve should be installed in the drain line in order to insure a sufficiently high oil level in the case.

Preferably, the drain line should be connected directly to the reservoir.

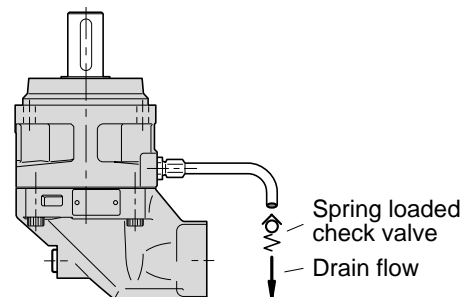

Before start-up

Make sure the F11/F12 case as well as the entire hydraulic system is filled with a recommended fluid. The internal leakage, especially at low operating pressures, is *not* sufficient to provide lubrication at start-up.

NOTE:

- To avoid cavitation and obtain a low noise level as well as reduced heat generation, tubes, hoses and fittings must be adequately dimensioned.
- Preferably, the suction line flow speed should be 0.5 to 1 m/s, and pressure line flow speeds 3 to 5 m/s.
- For series F12, suitable suction fittings are available (refer to page 29).



Please contact our sales representative:



Parker Hannifin
Mobile Controls Division
SE-461 82 Trollhättan
Sweden
Tel. +46 520 986 00
Fax +46 520 371 05
www.parker.com

Catalogue HY 17-8249/UK
Ed. 1754-0120